

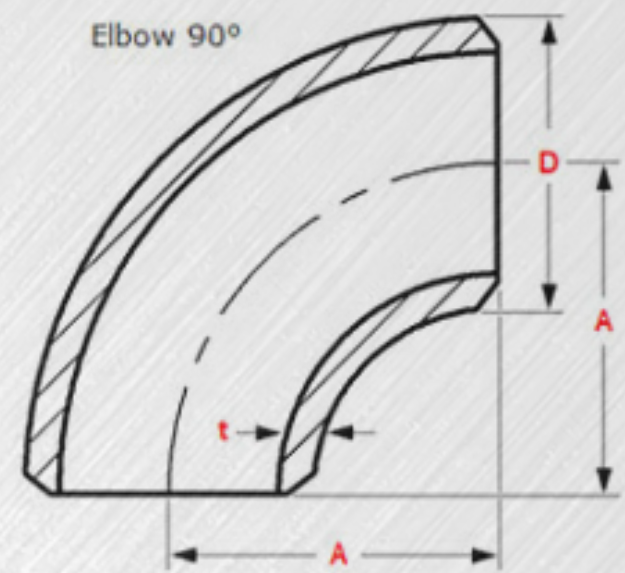

**Sourcing
Industrial
de México**

**CONEXIONES
CATÁLOGO
2023**

90° LONG RADIUS ELBOWS



DIMENSIONS

Unit : inch / lb

Nominal Pipe Size	Outside diameter (O.D)	Center to face (A)	Schedule 5S			Schedule 10S			Schedule 40S		
			Inside diameter (I.D.)	Wall thickness (T)	Approx. weight **	Inside diameter (I.D.)	Wall thickness (T)	Approx. weight **	Inside diameter (I.D.)	Wall thickness (T)	Approx. weight **
1/2	.840	1-1/2	.710	.065	.12	.674	.083	.14	.622	.109	.18
3/4	1.050	1-1/2	.920	.065	.13	.884	.083	.15	.824	.113	.19
1	1.315	1-1/2	1.185	.065	.19	1.097	.109	.30	1.049	.133	.35
1-1/4	1.660	1-7/8	1.530	.065	.31	1.442	.109	.50	1.380	.140	.56
1-1/2	1.900	2-1/4	1.770	.065	.38	1.682	.109	.69	1.610	.145	.88
2	2.375	3	2.245	.065	.64	2.157	.109	1.13	2.067	.154	1.56
2-1/2	2.875	3-3/4	2.709	.083	1.50	2.635	.120	1.88	2.469	.203	3.00
3	3.500	4-1/2	3.334	.083	2.00	3.260	.120	2.69	3.068	.216	4.81
3-1/2	4.000	5-1/4	3.834	.083	2.62	3.760	.120	3.75	3.548	.226	6.25
4	4.500	6	4.334	.083	3.31	4.260	.120	4.75	4.026	.237	9.19
5	5.563	7-1/2	5.345	.109	6.50	5.295	.134	8.00	5.047	.258	15.13
6	6.625	9	6.407	.109	10.00	6.357	.134	12.00	6.065	.280	24.00
8	8.625	12	8.407	.109	17.30	8.329	.148	23.50	7.981	.322	47.50
10	10.750	15	10.482	.134	32.00	10.420	.165	43.00	10.020	.365	85.00
12	12.750	18	12.438	.156	51.00	12.390	.180	60.00	12.000	.375	131.00
14	14.000	21	13.688	.156	68.00	13.624	.188	80.00	13.250	.375	155.00
16	16.000	24	15.670	.165	100.00	15.624	.188	105.00	15.250	.375	202.00
18	18.000	27	17.670	.165	125.00	17.624	.188	132.00	17.250	.375	269.00
20	20.000	30	19.624	.188	165.00	19.564	.218	220.00	19.250	.375	330.00
24	24.000	36	23.564	.218	280.00	23.500	.250	310.00	23.250	.375	464.00



90° LONG RADIUS ELBOWS

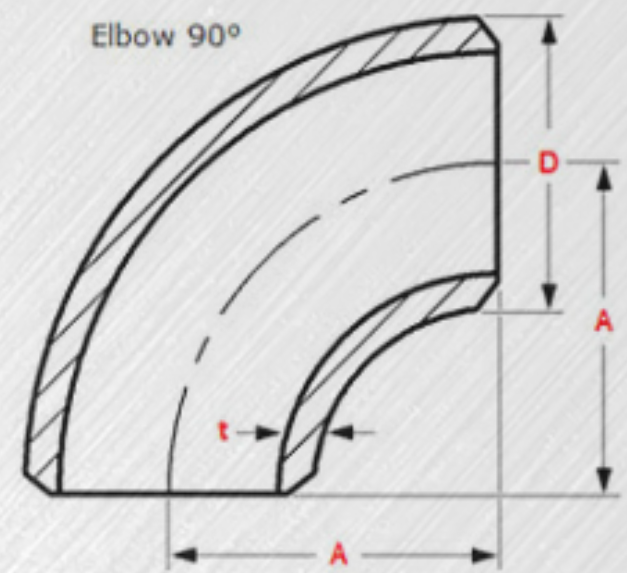

DIMENSIONS

Unit : inch / lb

Nominal Pipe Size	Outside diameter (O.D)	Center to face (A)	Schedule 80S			Schedule 160S			XX Strong Wall		
			Inside diameter (I.D.)	Wall thickness (T)	Approx. weight **	Inside diameter (I.D.)	Wall thickness (T)	Approx. weight **	Inside diameter (I.D.)	Wall thickness (T)	Approx. weight **
1	1.315	1	1.185	.065	.17	1.097	.109	.23	1.049	.133	.26
1-1/4	1.660	1-1/4	1.530	.065	.31	1.442	.109	.38	1.380	.140	.45
1-1/2	1.900	1-1/2	1.770	.065	.43	1.682	.109	.49	1.610	.145	.63
2	2.375	2	2.245	.065	.63	2.157	.109	.81	2.067	.154	1.13
2-1/2	2.875	2-1/2	2.709	.083	1.25	2.635	.120	1.36	2.469	.203	2.25
3	3.500	3	3.334	.083	1.75	3.260	.120	2.17	3.068	.216	3.31
3-1/2	4.000	3-1/2	3.834	.083	2.35	3.760	.120	3.05	3.548	.226	4.54
4	4.500	4	4.334	.083	3.12	4.260	.120	3.79	4.026	.237	6.88
5	5.563	5	5.345	.109	4.94	5.295	.134	6.12	5.047	.258	11.63
6	6.625	6	6.407	.109	7.75	6.357	.134	9.15	6.065	.280	17.50
8	8.625	8	8.407	.109	15.44	8.329	.148	17.63	7.981	.322	37.60
10	10.750	10	10.482	.134	27.40	10.420	.165	35.00	10.020	.365	63.00
12	12.750	12	12.438	.156	35.00	12.390	.180	40.00	12.000	.375	80.00
14	14.000	14	13.688	.156	44.00	13.624	.188	52.00	13.250	.375	101.00
16	16.000	16	15.670	.165	65.00	15.624	.188	68.00	15.250	.375	131.00
18	18.000	18	17.670	.165	81.00	17.624	.188	86.00	17.250	.375	175.00
20	20.000	20	19.624	.188	107.00	19.564	.218	143.00	19.250	.375	215.00
24	24.000	24	23.564	.218	182.00	23.500	.250	202.00	23.250	.375	302.00

90° SHORT RADIUS ELBOWS

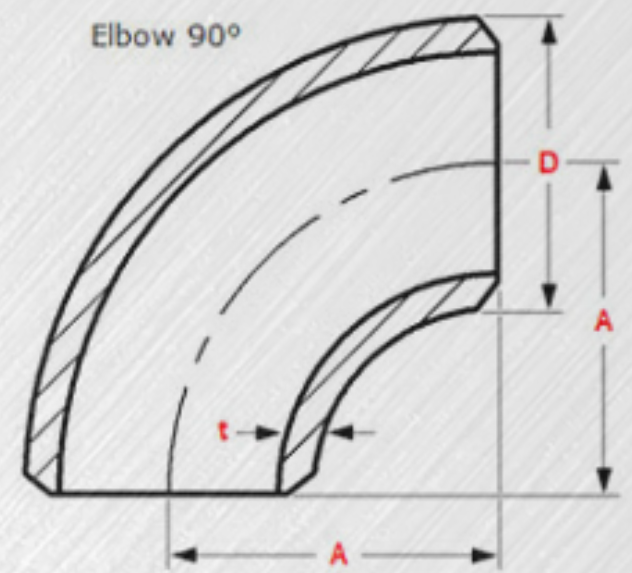

DIMENSIONS

Unit : inch / lb

Nominal Pipe Size	Outside diameter (O.D)	Center tu face (D)	Schedule 5S			Schedule 10S			Schedule 40S		
			Inside diameter (I.D.)	Wall thickness (T)	Approx. weight **	Inside diameter (I.D.)	Wall thickness (T)	Approx. weight **	Inside diameter (I.D.)	Wall thickness (T)	Approx. weight **
1/2	.840	1-1/2	.546	.147	.23	.464	.188	.29	.252	.294	.46
3/4	1.050	1-1/2	.742	.154	.25	.612	.219	.35	.434	.308	.50
1	1.315	1-1/2	.957	.179	.48	.815	.250	.67	.599	.358	.96
1-1/4	1.660	1-7/8	1.278	.191	.88	1.160	.250	1.15	.896	.382	1.76
1-1/2	1.900	2-1/4	1.500	.200	1.13	1.338	.281	1.59	1.100	.400	2.26
2	2.375	3	1.939	.218	2.00	1.689	.343	3.14	1.503	.436	4.00
2-1/2	2.875	3-3/4	2.323	.276	4.00	2.125	.375	5.44	1.771	.552	8.00
3	3.500	4-1/2	2.900	.300	6.56	2.624	.438	9.58	2.300	.600	13.12
3-1/2	4.000	5-1/4	3.364	.318	8.80	-----	-----	-----	2.728	.636	17.60
4	4.500	6	3.826	.337	13.63	3.438	.531	21.53	3.152	.674	27.26
5	5.563	7-1/2	4.813	.375	21.13	4.313	.625	35.29	4.063	.750	42.26
6	6.625	9	5.761	.432	36.00	5.187	.719	59.76	4.897	.864	72.00
8	8.625	12	7.625	.500	73.00	6.813	.906	132.00	6.875	.875	127.00
10	10.750	15	9.750	.500	114.00	8.500	1.125	256.00	-----	-----	-----
12	12.750	18	11.750	.500	175.00	10.126	1.312	458.00	-----	-----	-----
14	14.000	21	13.000	.500	206.00	11.188	1.406	-----	-----	-----	-----
16	16.000	24	15.000	.500	269.00	12.812	1.594	-----	-----	-----	-----
18	18.000	27	17.000	.500	350.00	14.438	1.781	-----	-----	-----	-----
20	20.000	30	19.000	.500	439.00	16.062	1.969	-----	-----	-----	-----
24	24.000	36	23.000	.500	617.00	19.312	2.344	-----	-----	-----	-----



90° SHORT RADIUS ELBOWS

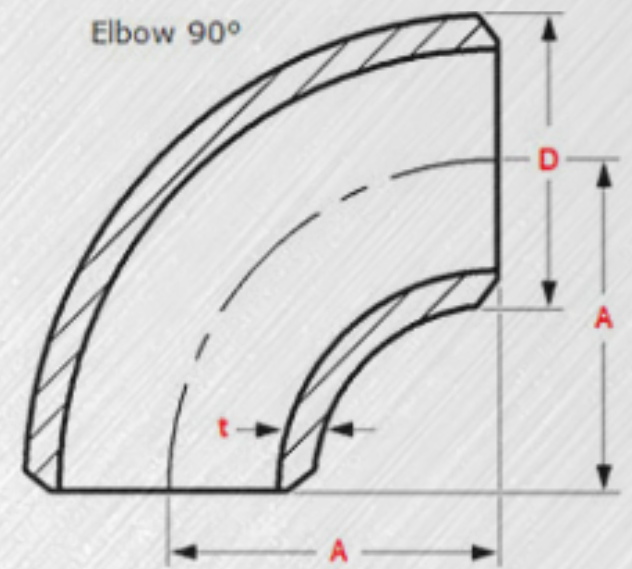

DIMENSIONS

Unit : inch / lb

Nominal Pipe Size	Outside diameter (O.D)	Center to face (D)	Schedule 80S			Schedule 160S			XX Strong Wall		
			Inside diameter (I.D.)	Wall thickness (T)	Approx. weight **	Inside diameter (I.D.)	Wall thickness (T)	Approx. weight **	Inside diameter (I.D.)	Wall thickness (T)	Approx. weight **
1	1.315	1	.957	.179	.38	.815	.250	.53	.599	.358	.76
1-1/4	1.660	1-1/4	1.278	.191	.63	1.160	.250	.82	.896	.382	1.26
1-1/2	1.900	1-1/2	1.500	.200	.88	1.338	.281	1.23	1.100	.400	1.76
2	2.375	2	1.939	.218	1.55	1.689	.343	2.43	1.503	.436	3.10
2-1/2	2.875	2-1/2	2.323	.276	2.88	2.125	.375	3.88	1.771	.552	5.76
3	3.500	3	2.900	.300	4.20	2.624	.438	6.09	2.300	.600	8.40
3-1/2	4.000	3-1/2	3.364	.318	5.35	-----	-----	-----	2.728	.636	10.70
4	4.500	4	3.826	.337	9.06	3.438	.531	14.22	3.152	.674	18.12
5	5.563	5	4.813	.375	16.10	4.313	.625	26.72	4.063	.750	32.20
6	6.625	6	5.761	.432	26.00	5.187	.719	43.16	4.897	.864	52.00
8	8.625	8	7.625	.500	54.80	6.813	.906	99.18	6.875	.875	109.00
10	10.750	10	9.750	.500	99.80	8.500	1.125	224.00	-----	-----	-----
12	12.750	12	11.750	.500	125.00	10.126	1.312	327.00	-----	-----	-----
14	14.000	14	13.000	.500	135.00	11.188	1.406	-----	-----	-----	-----
16	16.000	16	15.000	.500	175.00	12.812	1.594	-----	-----	-----	-----
18	18.000	18	17.000	.500	228.00	14.438	1.781	-----	-----	-----	-----
20	20.000	20	19.000	.500	285.00	16.062	1.969	-----	-----	-----	-----
24	24.000	24	23.000	.500	401.00	19.312	2.344	-----	-----	-----	-----



45° LONG RADIUS ELBOWS

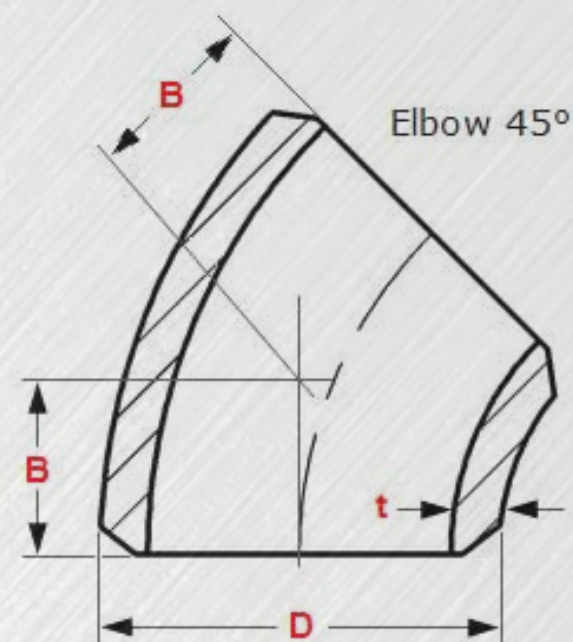

DIMENSIONS

Unit : inch / lb

Nominal Pipe Size	Outside diameter (O.D)	Center tu face (B)	Schedule 5S			Schedule 10S			Schedule 40S		
			Inside diameter (I.D.)	Wall thickness (T)	Approx. weight **	Inside diameter (I.D.)	Wall thickness (T)	Approx. weight **	Inside diameter (I.D.)	Wall thickness (T)	Approx. weight **
1/2	.840	5/8	.710	.065	.06	.674	.083	.07	.622	.109	.09
3/4	1.050	7/16	.920	.065	.06	.884	.083	.07	.824	.113	.09
1	1.315	7/8	1.185	.065	.12	1.097	.109	.19	1.049	.133	.25
1-1/4	1.660	1	1.530	.065	.19	1.442	.109	.25	1.380	.140	.38
1-1/2	1.900	1-1/8	1.770	.065	.25	1.682	.109	.38	1.610	.145	.50
2	2.375	1-3/8	2.245	.065	.31	2.157	.109	.56	2.067	.154	.88
2-1/2	2.875	1-3/4	2.709	.083	.75	2.635	.120	1.06	2.469	.203	1.69
3	3.500	2	3.334	.083	1.06	3.260	.120	1.38	3.068	.216	2.38
3-1/2	4.000	2-1/4	3.834	.083	1.16	3.760	.120	1.66	3.548	.226	3.13
4	4.500	2-1/2	4.334	.083	1.66	4.260	.120	2.38	4.026	.237	4.60
5	5.563	3-1/8	5.345	.109	3.25	5.295	.134	4.00	5.047	.258	7.57
6	6.625	3-3/4	6.407	.109	5.00	6.357	.134	6.00	6.065	.280	12.00
8	8.625	5	8.407	.109	8.65	8.329	.148	11.75	7.981	.322	23.75
10	10.750	6-1/4	10.482	.134	16.00	10.420	.165	21.50	10.020	.365	42.50
12	12.750	7-1/2	12.438	.156	25.50	12.390	.180	30.00	12.000	.375	65.50
14	14.000	8-3/4	13.688	.156	34.00	13.624	.188	40.00	13.250	.375	77.50
16	16.000	10	15.670	.165	50.00	15.624	.188	52.50	15.250	.375	101.00
18	18.000	11-1/4	17.670	.165	62.50	17.624	.188	66.00	17.250	.375	131.00
20	20.000	12-1/2	19.624	.188	82.50	19.564	.218	110.00	19.250	.375	165.00
24	24.000	15	23.564	.218	140.00	23.500	.250	155.00	23.250	.375	232.00



45° LONG RADIUS ELBOWS

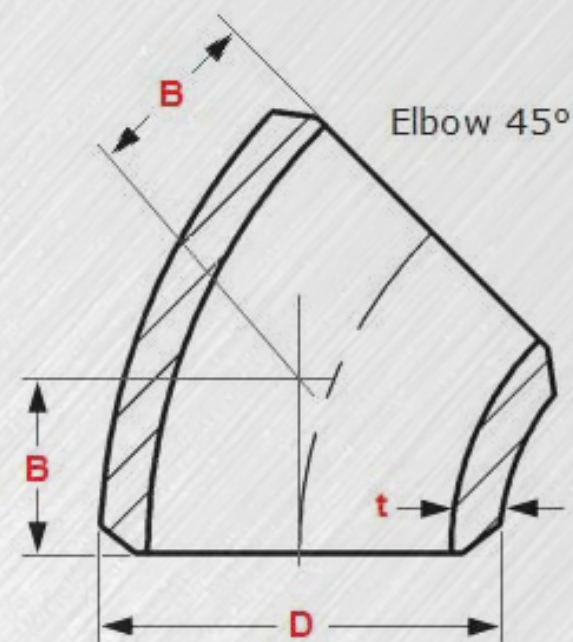

DIMENSIONS

Unit : inch / lb

Nominal Pipe Size	Outside diameter (O.D)	Center tu face (B)	Schedule 80S			Schedule 160S			XX Strong Wall		
			Inside diameter (I.D.)	Wall thickness (T)	Approx. weight **	Inside diameter (I.D.)	Wall thickness (T)	Approx. weight **	Inside diameter (I.D.)	Wall thickness (T)	Approx. weight **
1/2	.840	5/8	.546	.147	.12	.464	.188	.16	.252	.294	.24
3/4	1.050	7/16	.742	.154	.12	.612	.219	.16	.434	.308	.24
1	1.315	7/8	.957	.179	.31	.815	.250	.43	.599	.358	.62
1-1/4	1.660	1	1.278	.191	.50	1.160	.250	.85	.896	.382	1.00
1-1/2	1.900	1-1/8	1.500	.200	.63	1.338	.281	.88	1.100	400	1.26
2	2.375	1-3/8	1.939	.218	1.13	1.689	.343	1.77	1.503	436	2.26
2-1/2	2.875	1-3/4	2.323	.276	2.19	2.125	.375	2.95	1.771	552	4.38
3	3.500	2	2.900	.300	3.31	2.624	.438	4.80	2.300	600	6.62
3-1/2	4.000	2-1/4	3.364	.318	4.40	-----	-----	-----	2.728	.636	8.80
4	4.500	2-1/2	3.826	.337	6.82	3.438	.531	10.87	3.152	.674	13.64
5	5.563	3-1/8	4.813	.375	10.56	4.313	.625	17.52	4.063	.750	21.12
6	6.625	3-3/4	5.761	.432	18.00	5.187	.719	20.88	4.897	.864	36.00
8	8.625	5	7.625	.500	36.50	6.813	.906	64.24	6.875	.875	63.87
10	10.750	6-1/4	9.750	.500	57.00	8.500	1.125	127.00	-----	-----	-----
12	12.750	7-1/2	11.750	.500	87.50	10.126	1.312	229.00	-----	-----	-----
14	14.000	8-3/4	13.000	.500	103.00	11.188	1.406	-----	-----	-----	-----
16	16.000	10	15.000	.500	134.00	12.812	1.594	-----	-----	-----	-----
18	18.000	11-1/4	17.000	.500	175.00	14.438	1.781	-----	-----	-----	-----
20	20.000	12-1/2	19.000	.500	219.00	16.062	1.969	-----	-----	-----	-----
24	24.000	15	23.000	.500	308.00	19.312	2.344	-----	-----	-----	-----



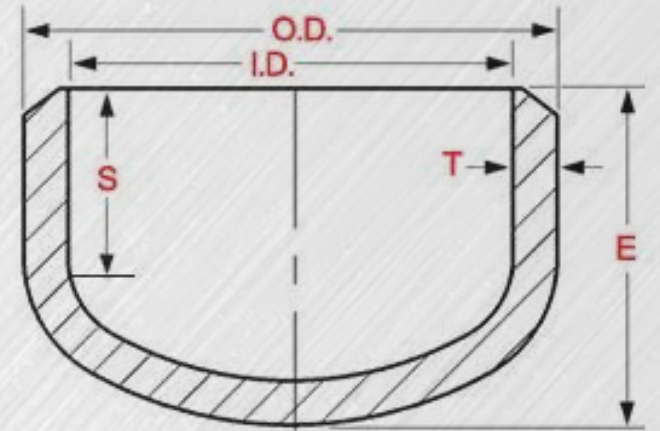

DIMENSIONS

Unit : inch / lb

Nominal Pipe Size	Outside diameter (O.D)	Length (E)	Tangent Length (S)	Schedule 5S			Schedule 10S			Schedule 40S		
				Inside diameter (I.D.)	Wall thickness (T)	Approx. weight **	Inside diameter (I.D.)	Wall thickness (T)	Approx. weight **	Inside diameter (I.D.)	Wall thickness (T)	Approx. weight **
1/2	.840	1	.74	.710	.065	.08	.674	.083	.09	.622	.109	.10
3/4	1.050	1	.68	.920	.065	.11	.884	.083	.12	.824	.113	.13
1	1.315	1-1/2	1.10	1.185	.065	.18	1.097	.109	.19	1.049	.133	.28
1-1/4	1.660	1-1/2	1.02	1.530	.065	.20	1.442	.109	.28	1.380	.140	.38
1-1/2	1.900	1-1/2	.95	1.770	.065	.22	1.682	.109	.31	1.610	.145	.50
2	2.375	1-1/2	.83	2.245	.065	.36	2.157	.109	.38	2.067	.154	.60
2-1/2	2.875	1-1/2	.68	2.709	.083	.50	2.635	.120	.56	2.469	.203	1.00
3	3.500	2	1.02	3.334	.083	.86	3.260	.120	.88	3.068	.216	1.56
3-1/2	4.000	2-1/2	1.40	3.834	.083	1.20	3.760	.120	1.25	3.548	.226	2.25
4	4.500	2-1/2	1.26	4.334	.083	1.25	4.260	.120	1.44	4.026	.237	2.69
5	5.563	3	1.48	5.345	.109	2.00	5.295	.134	2.25	5.047	.258	4.06
6	6.625	3-1/2	1.70	6.407	.109	2.75	6.357	.134	3.00	6.065	.280	7.12
8	8.625	4	1.68	8.407	.109	4.50	8.329	.148	5.50	7.981	.322	12.50
10	10.750	5	2.13	10.482	.134	9.50	10.420	.165	10.80	10.020	.365	20.30
12	12.750	6	2.63	12.438	.156	14.00	12.390	.180	14.40	12.000	.375	28.80
14	14.000	6-1/2	2.81	13.688	.156	17.00	13.624	.188	18.00	13.250	.375	35.70
16	16.000	7	2.81	15.670	.165	30.00	15.624	.188	32.00	15.250	.375	48.50
18	18.000	8	3.31	17.670	.165	38.00	17.624	.188	39.60	17.250	.375	59.40
20	20.000	9	3.81	19.624	.188	55.00	19.564	.218	60.00	19.250	.375	75.00
24	24.000	10-1/2	4.31	23.564	.218	75.00	23.500	.250	76.00	23.250	.375	98.00



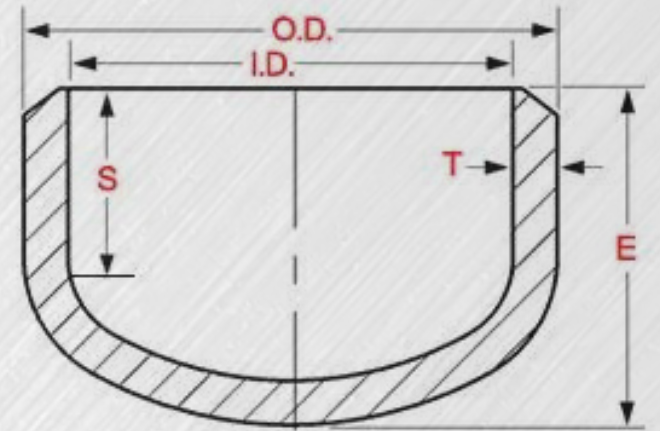

DIMENSIONS

Unit : inch / lb

Nominal Pipe Size	Outside diameter (O.D)	Lenght (E) Tangent Lenght (S)	Lenght (E1) Tangent Lenght (S)	Schedule 80S			Schedule 160S			XX Strong Wall		
				Inside diameter (I.D.)	Wall thickness (T)	Approx. weight **	Inside diameter (I.D.)	Wall thickness (T)	Approx. weight **	Inside diameter (I.D.)	Wall thickness (T)	Approx. weight **
1/2	.840	E 1 S .72	E1 1 S .64	.546	.147	.11	.464	.188	.14	.252	.294	.22
3/4	1.050	E 1 S .66	E1 1 S .58	.742	.154	.14	.612	.219	.20	.434	.308	.28
1	1.315	E 1-1/2 S 1.08	E1 1-1/2 S .99	.957	.179	.29	.815	.250	.40	.599	.358	.58
1-1/4	1.660	E 1-1/2 S .93	E1 1-1/2 S .83	1.278	.191	.39	1.160	.250	.50	.896	.382	.78
1-1/2	1.900	E 1-1/2 S .80	E1 1-3/4 S .95	1.939	.218	.75	1.689	.343	1.17	1.503	.436	1.50
2	2.375	E 1-1/2 S .64	E1 2 S 1.01	2.323	.276	1.12	2.125	.375	1.48	1.771	.552	2.24
3	3.500	E 2 S .98	E1 2-1/2 S 1.32	2.900	.300	1.87	2.624	.438	2.71	2.300	.600	3.74
3-1/2	4.000	E 2-1/2 S 1.34	E1 3 S 1.70	3.364	.318	2.50	-----	-----	-----	2.728	.636	5.00
4	4.500	E 2-1/2 S 1.21	E1 3 S 1.60	3.826	.337	3.54	3.438	.531	5.55	3.152	.674	7.08
5	5.563	E 3 S 1.42	E1 3-1/2 S 1.73	4.813	.375	5.63	4.313	.625	9.34	4.063	.750	11.26
6	6.625	E 3-1/2 S 1.63	E1 4 S 1.91	5.761	.432	10.00	5.187	.719	16.00	4.897	.864	20.00
8	8.625	E 4 S 1.59	E1 5 S 2.41	7.625	.500	16.38	6.813	.906	29.64	6.875	.875	22.76
10	10.750	E 5 S 2.06	E1 6 S 2.75	9.750	.500	27.30	8.500	1.125	61.42	-----	-----	-----
12	12.750	E 6 S 2.56	E1 7 S 3.16	11.750	.500	36.60	10.126	1.312	95.00	-----	-----	-----
14	14.000	E 6-1/2 S 2.75	-----	13.000	.500	48.00	11.188	1.406	-----	-----	-----	-----
16	16.000	E 7 S 2.75	-----	15.000	.500	65.00	12.812	1.594	-----	-----	-----	-----
18	18.000	E 8 S 3.25	-----	17.000	.500	79.20	14.438	1.781	-----	-----	-----	-----
20	20.000	E 9 S 3.75	-----	19.000	.500	88.00	16.062	1.969	-----	-----	-----	-----
24	24.000	E 10-1/2 S 4.25	-----	23.000	.500	135.00	19.312	2.344	-----	-----	-----	-----



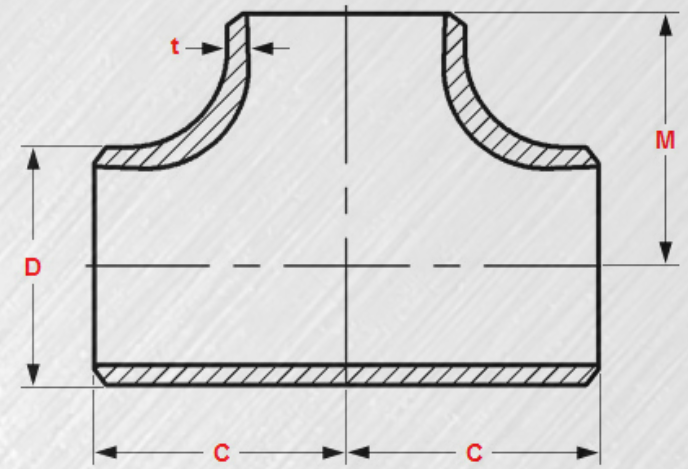

DIMENSIONS

Unit : inch / lb

Nominal Pipe Size	Outside diameter (O.D)	Center tu end (C)	Schedule 5S			Schedule 10S			Schedule 40S		
			Inside diameter (I.D.)	Wall thickness (T)	Approx. weight **	Inside diameter (I.D.)	Wall thickness (T)	Approx. weight **	Inside diameter (I.D.)	Wall thickness (T)	Approx. weight **
1/2	.840	1	.710	.065	.19	.674	.083	.21	.622	.109	.23
3/4	1.050	1-1/8	.920	.065	.22	.884	.083	.28	.824	.113	.38
1	1.315	1-1/2	1.185	.065	.40	1.097	.109	.63	1.049	.133	.65
1-1/4	1.660	1-7/8	1.530	.065	.75	1.442	.109	1.10	1.380	.140	1.31
1-1/2	1.900	2-1/4	1.770	.065	.95	1.682	.109	1.50	1.610	.145	1.90
2	2.375	2-1/2	2.245	.065	1.20	2.157	.109	1.87	2.067	.154	2.83
2-1/2	2.875	3	2.709	.083	2.15	2.635	.120	3.10	2.469	.203	4.85
3	3.500	3-3/8	3.334	.083	3.40	3.260	.120	3.90	3.068	.216	7.30
3-1/2	4.000	3-3/4	3.834	.083	5.50	3.760	.120	5.88	3.548	.226	9.00
4	4.500	4-1/8	4.334	.083	7.20	4.260	.120	7.63	4.026	.237	11.63
5	5.563	4-7/8	5.345	.109	13.00	5.295	.134	13.45	5.047	.258	20.75
6	6.625	5-5/8	6.407	.109	17.20	6.357	.134	17.80	6.065	.280	24.25
8	8.625	7	8.407	.109	31.00	8.329	.148	34.50	7.981	.322	46.10
10	10.750	8-1/2	10.482	.134	55.00	10.420	.165	59.00	10.020	.365	78.00
12	12.750	10	12.438	.156	83.00	12.390	.180	87.00	12.000	.375	137.00
14	14.000	11	13.688	.156	89.00	13.624	.188	107.00	13.250	.375	175.00
16	16.000	12	15.670	.165	115.00	15.624	.188	130.00	15.250	.375	220.00
18	18.000	13-1/2	17.670	.165	149.00	17.624	.188	169.00	17.250	.375	286.00
20	20.000	15	19.624	.188	171.00	19.564	.218	228.00	19.250	.375	358.00
24	24.000	17	23.564	.218	298.00	23.500	.250	343.00	23.250	.375	498.00



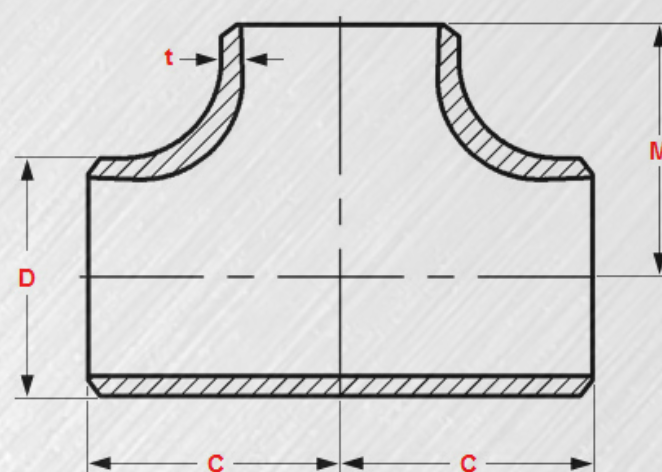

DIMENSIONS

Unit : inch / lb

Nominal Pipe Size	Outside diameter (O.D)	Center tu end (C)	Schedule 80S			Schedule 160S			XX Strong Wall		
			Inside diameter (I.D.)	Wall thickness (T)	Approx. weight **	Inside diameter (I.D.)	Wall thickness (T)	Approx. weight **	Inside diameter (I.D.)	Wall thickness (T)	Approx. weight **
1/2	.840	1	.546	.147	.30	.464	.188	.38	.252	.294	.60
3/4	1.050	1-1/8	.742	.154	.45	.612	.219	.64	.434	.308	.90
1	1.315	1-1/2	.957	.179	.85	.815	.250	1.19	.599	.358	1.70
1-1/4	1.660	1-7/8	1.278	.191	1.50	1.160	.250	1.97	.896	.382	3.00
1-1/2	1.900	2-1/4	1.500	.200	2.25	1.338	.281	3.15	1.100	.400	4.50
2	2.375	2-1/2	1.939	.218	3.50	1.689	.343	5.50	1.503	.436	7.00
2-1/2	2.875	3	2.323	.276	6.90	2.125	.375	9.38	1.771	.552	13.80
3	3.500	3-3/8	2.900	.300	9.80	2.624	.438	14.31	2.300	.600	19.60
3-1/2	4.000	3-3/4	3.364	.318	12.00	-----	-----	-----	2.728	.636	24.00
4	4.500	4-1/8	3.826	.337	17.00	3.438	.531	26.86	3.152	.674	34.00
5	5.563	4-7/8	4.813	.375	25.00	4.313	.625	41.75	4.063	.750	50.00
6	6.625	5-5/8	5.761	.432	30.00	5.187	.719	49.80	4.897	.864	60.00
8	8.625	7	7.625	.500	62.00	6.813	.906	112.00	6.875	.875	108.00
10	10.750	8-1/2	9.750	.500	110.00	8.500	1.125	247.00	-----	-----	-----
12	12.750	10	11.750	.500	185.00	10.126	1.312	484.00	-----	-----	-----
14	14.000	11	13.000	.500	210.00	11.188	1.406	590.00	-----	-----	-----
16	16.000	12	15.000	.500	265.00	12.812	1.594	812.00	-----	-----	-----
18	18.000	13-1/2	17.000	.500	344.00	14.438	1.781	1097.00	-----	-----	-----
20	20.000	15	19.000	.500	430.00	16.062	1.969	1690.00	-----	-----	-----
24	24.000	17	23.000	.500	600.00	19.312	2.344	2950.00	-----	-----	-----



REDUCING OUTLET TEES

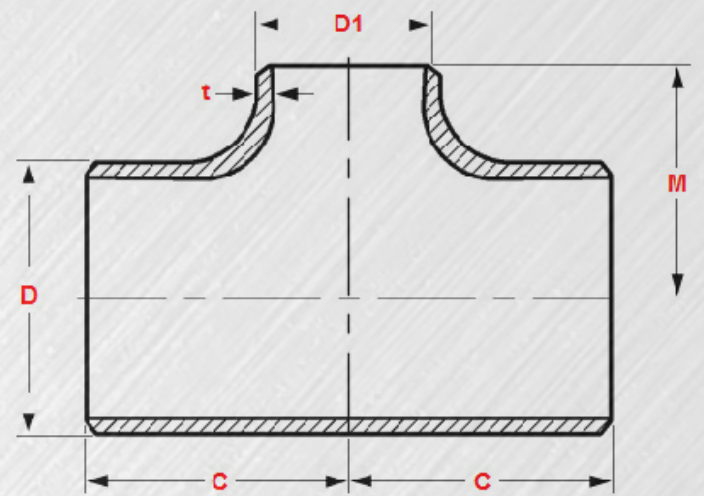

DIMENSIONS

Unit : inch / lb

Nominal Pipe Size Run X Outlet	Outside Diameter Run (O.D)	Outside Diameter Outlet (O.D)	Center to End Run (C)	Center to End Outlet (M)	Schedule 5S					Schedule 10S					Schedule 40S				
					Inside Diameter Run (I.D.)	Inside Diameter Outlet (I.D.)	Wall thickness Run (T)	Wall thickness Outlet (T)	Approx. weight **	Inside Diameter Run (I.D.)	Inside Diameter Outlet (I.D.)	Wall thickness Run (T)	Wall thickness Outlet (T)	Approx. weight **	Inside Diameter Run (I.D.)	Inside Diameter Outlet (I.D.)	Wall thickness Run (T)	Wall thickness Outlet (T)	Approx. weight **
1/2x1/4	.840	.540	1	1	.710	.410	.065	.065	.16	.674	.410	.083	.065	.18	.622	.364	.109	.088	.20
1/2x3/8	.840	.675	1	1	.710	.545	.065	.065	.17	.674	.545	.083	.065	.19	.622	.493	.109	.091	.21
3/4x3/8	1.050	.675	1-1/8	1-1/8	.920	.545	.065	.065	.19	.884	.545	.083	.065	.24	.824	.493	.113	.091	.32
3/4x1/2	1.050	.840	1-1/8	1-1/8	.920	.710	.065	.065	.20	.884	.674	.083	.083	.25	.824	.622	.113	.109	.34
1x3/8	1.315	.675	1-1/2	1-1/2	1.185	.545	.065	.065	.34	1.097	.545	.109	.065	.54	1.049	.493	.133	.091	.56
1x1/2	1.315	.840	1-1/2	1-1/2	1.185	.710	.065	.065	.35	1.097	.674	.109	.083	.55	1.049	.622	.133	.109	.57
1x3/4	1.315	1.050	1-1/2	1-1/2	1.185	.920	.065	.065	.36	1.097	.884	.109	.083	.56	1.049	.824	.133	.113	.59
1-1/4x1/2	1.660	.840	1-7/8	1-7/8	1.530	.710	.065	.065	.64	1.442	.674	.109	.083	.95	1.380	.622	.140	.109	1.12
1-1/4x3/4	1.660	1.050	1-7/8	1-7/8	1.530	.920	.065	.065	.66	1.442	.884	.109	.083	.97	1.380	.824	.140	.113	1.15
1-1/4x1	1.660	1.315	1-7/8	1-7/8	1.530	1.185	.065	.065	.68	1.442	1.097	.109	.109	.99	1.380	1.049	.140	.133	1.17
1-1/2x1/2	1.900	.840	2-1/4	2-1/4	1.770	.710	.065	.065	.81	1.682	.674	.109	.083	1.27	1.610	.622	.145	.109	1.61
1-1/2x3/4	1.900	1.050	2-1/4	2-1/4	1.770	.920	.065	.065	.82	1.682	.884	.109	.083	1.29	1.610	.824	.145	.113	1.63
1-1/2x1	1.900	1.315	2-1/4	2-1/4	1.770	1.185	.065	.065	.83	1.682	1.097	.109	.109	1.32	1.610	1.049	.145	.133	1.67
1-1/2x1-1/4	1.900	1.660	2-1/4	2-1/4	1.770	1.530	.065	.065	.85	1.682	1.442	.109	.109	1.35	1.610	1.380	.145	.140	1.71
2x3/4	2.375	1.050	2-1/2	1-3/4	2.245	.920	.065	.065	1.02	2.157	.884	.109	.083	1.59	2.067	.824	.154	.113	2.40
2x1	2.375	1.315	2-1/2	2	2.245	1.185	.065	.065	1.03	2.157	1.097	.109	.109	1.60	2.067	1.049	.154	.133	2.43
2x1-1/4	2.375	1.660	2-1/2	2-1/4	2.245	1.530	.065	.065	1.05	2.157	1.442	.109	.109	1.64	2.067	1.380	.154	.140	2.49
2x1-1/2	2.375	1.900	2-1/2	2-3/8	2.245	1.770	.065	.065	1.08	2.157	1.682	.109	.109	1.68	2.067	1.610	.154	.145	2.54
2-1/2x1	2.875	1.315	3	2-1/4	2.709	1.185	.083	.065	1.83	2.635	1.097	.120	.109	2.63	2.469	1.049	.203	.133	4.12
2-1/2x1-1/4	2.875	1.660	3	2-1/2	2.709	1.530	.083	.065	1.85	2.635	1.442	.120	.109	2.66	2.469	1.380	.203	.140	4.17
2-1/2x1-1/2	2.875	1.900	3	2-5/8	2.709	1.770	.083	.065	1.89	2.635	1.682	.120	.109	2.73	2.469	1.610	.203	.145	4.27
2-1/2x2	2.875	2.375	3	2-3/4	2.709	2.245	.083	.065	1.93	2.635	2.157	.120	.109	2.79	2.469	2.067	.203	.154	4.36
3x1	3.500	1.315	3-3/8	2-5/8	3.334	1.185	.083	.065	2.85	3.260	1.097	.120	.109	3.27	3.068	1.049	.216	.133	6.13
3x1-1/4	3.500	1.660	3-3/8	2-3/4	3.334	1.530	.083	.065	2.89	3.260	1.442	.120	.109	3.31	3.068	1.380	.216	.140	6.20
3x1-1/2	3.500	1.900	3-3/8	2-7/8	3.334	1.770	.083	.065	2.93	3.260	1.682	.120	.109	3.35	3.068	1.610	.216	.145	6.28
3x2	3.500	2.375	3-3/8	3	3.334	2.245	.083	.065	2.99	3.260	2.157	.120	.109	3.43	3.068	2.067	.216	.154	6.42
3x2-1/2	3.500	2.875	3-3/8	3-1/4	3.334	2.709	.083	.083	3.06	3.260	2.635	.120	.120	3.51	3.068	2.469	.216	.203	6.57
3-1/2x1-1/2	4.000	1.900	3-3/4	3-1/8	3.834	1.770	.083	.065	4.67	3.760	1.682	.120	.109	4.99	3.548	1.610	.226	.145	7.65
3-1/2x2	4.000	2.375	3-3/4	3-1/4	3.834	2.245	.083	.065	4.73	3.760	2.157	.120	.109	5.05	3.548	2.067	.226	.154	7.74
3-1/2x2-1/2	4.000	2.875	3-3/4	3-1/2	3.834	2.709	.083	.083	4.84	3.760	2.635	.120	.120	5.17	3.548	2.469	.226	.203	8.97
3-1/2x3	4.000	3.500	3-3/4	3-5/8	3.834	3.334	.083	.083	4.95	3.760	3.260	.120	.120	5.29	3.548	3.068	.226	.216	9.10
4x1-1/2	4.500	1.900	4-1/8	3-3/8	4.334	1.770	.083	.065	6.05	4.260	1.682	.120	.109	6.40	4.026	1.610	.237	.145	9.76
4x2	4.500	2.375	4-1/8	3-1/2	4.334	2.245	.083	.065	6.12	4.260	2.157	.120	.109	6.48	4.026	2.067	.237	.154	9.88
4x2-1/2	4.500	2.875	4-1/8	3-3/4	4.334	2.709	.083	.083	6.19	4.260	2.635	.120	.120	6.56	4.026	2.469	.237	.203	10.00
4x3	4.500	3.500	4-1/8	3-7/8	4.334	3.334	.083	.083	6.33	4.260	3.260	.120	.120	6.71	4.026	3.068	.237	.216	10.23
4x3-1/2	4.500	4.000	4-1/8	4	4.334	3.834	.083	.083	6.48	4.260	3.760	.120	.120	6.86	4.026	3.548	.237	.226	10.40



REDUCING OUTLET TEES

DIMENSIONS

Unit : inch / lb

Nominal Pipe Size Run X Outlet	Outside Diameter Run (O.D.)	Outside Diameter Outlet (O.D.)	Center to End Run (C)	Center to End Outlet (M)	Schedule 5S					Schedule 10S					Schedule 40S				
					Inside Diameter Run (I.D.)	Inside Diameter Outlet (I.D.)	Wall thickness Run (T)	Wall thickness Outlet (T)	Approx. weight **	Inside Diameter Run (I.D.)	Inside Diameter Outlet (I.D.)	Wall thickness Run (T)	Wall thickness Outlet (T)	Approx. weight **	Inside Diameter Run (I.D.)	Inside Diameter Outlet (I.D.)	Wall thickness Run (T)	Wall thickness Outlet (T)	Approx. weight **
5 x 2	5.563	2.375	4-7/8	4-1/8	5.345	2.245	.109	.065	10.92	5.295	2.157	.134	.109	11.29	5.047	2.067	.258	.154	17.43
5 x 2-1/2	5.563	2.875	4-7/8	4-1/4	5.345	2.709	.109	.083	11.05	5.295	2.635	.134	.120	11.43	5.047	2.469	.258	.203	17.63
5 x 3	5.563	3.500	4-7/8	4-3/8	5.345	3.334	.109	.083	11.18	5.295	3.260	.134	.120	11.56	5.047	3.068	.258	.216	17.84
5 x 3-1/2	5.563	4.000	4-7/8	4-1/2	5.345	3.834	.109	.083	11.44	5.295	3.760	.134	.120	11.83	5.047	3.548	.258	.226	18.26
5 x 4	5.563	4.500	4-7/8	4-5/8	5.345	4.334	.109	.083	11.70	5.295	4.260	.134	.120	12.10	5.047	4.026	.258	.237	18.67
6 x 2-1/2	6.625	2.875	5-5/8	4-3/4	6.407	2.709	.109	.083	14.48	6.357	2.635	.134	.120	14.95	6.065	2.469	.280	.203	20.37
6 x 3	6.625	3.500	5-5/8	4-7/8	6.407	3.334	.109	.083	14.62	6.357	3.260	.134	.120	15.13	6.065	3.068	.280	.216	26.32
6 x 3-1/2	6.625	4.000	5-5/8	5	6.407	3.834	.109	.083	14.79	6.357	3.760	.134	.120	15.31	6.065	3.548	.280	.226	20.85
6 x 4	6.625	4.500	5-5/8	5-1/8	6.407	4.334	.109	.083	15.13	6.357	4.260	.134	.120	15.66	6.065	4.026	.280	.237	21.34
6 x 5	6.625	5.563	5-5/8	5-3/8	6.407	5.345	.109	.109	15.48	6.357	5.295	.134	.134	16.02	6.065	5.047	.280	.258	21.82
8 x 3	8.625	3.500	7	6	8.407	3.334	.109	.083	26.04	8.329	3.260	.148	.120	29.00	7.981	3.068	.322	.216	38.72
8 x 3-1/2	8.625	4.000	7	6	8.407	3.834	.109	.083	26.35	8.329	3.760	.148	.120	29.32	7.981	3.548	.322	.226	39.18
8 x 4	8.625	4.500	7	6-1/8	8.407	4.334	.109	.083	26.66	8.329	4.260	.148	.120	29.67	7.981	4.026	.322	.237	39.64
8 x 5	8.625	5.563	7	6-3/8	8.407	5.345	.109	.109	27.28	8.329	5.295	.148	.134	30.36	7.981	5.047	.322	.258	40.56
8 x 6	8.625	6.625	7	6-5/8	8.407	6.407	.109	.109	27.90	8.329	6.357	.148	.134	31.05	7.981	6.065	.322	.280	41.49
10 x 4	10.750	4.500	8-1/2	7-1/4	10.482	4.334	.134	.083	46.75	10.420	4.260	.165	.120	50.15	10.020	4.026	.365	.237	66.30
10 x 5	10.750	5.563	8-1/2	7-1/2	10.482	5.345	.134	.109	47.30	10.420	5.295	.165	.134	50.74	10.020	5.047	.365	.258	67.08
10 x 6	10.750	6.625	8-1/2	7-5/8	10.482	6.407	.134	.109	48.40	10.420	6.357	.165	.134	51.92	10.020	6.065	.365	.280	68.64
10 x 8	10.750	8.625	8-1/2	8	10.482	8.407	.134	.109	49.50	10.420	8.329	.165	.148	53.10	10.020	7.981	.365	.322	70.20
12 x 5	12.750	5.563	10	8-1/2	12.438	5.345	.156	.109	70.55	12.390	5.295	.180	.134	73.95	12.000	5.047	.375	.258	116.00
12 x 6	12.750	6.625	10	8-5/8	12.438	6.407	.156	.109	71.38	12.390	6.357	.180	.134	74.82	12.000	6.065	.375	.280	118.00
12 x 8	12.750	8.625	10	9	12.438	8.407	.156	.109	73.04	12.390	8.329	.180	.148	76.56	12.000	7.981	.375	.322	120.00
12 x 10	12.750	10.750	10	9-1/2	12.438	10.482	.156	.134	74.70	12.390	10.420	.180	.165	78.30	12.000	10.020	.375	.365	123.00
14 x 6	14.000	6.625	11	9-3/8	13.688	6.407	.156	.109	75.65	13.624	6.357	.188	.134	90.95	13.250	6.065	.375	.280	148.00
14 x 8	14.000	8.625	11	9-3/4	13.688	8.407	.156	.109	76.54	13.624	8.329	.188	.148	92.02	13.250	7.981	.375	.322	150.00
14 x 10	14.000	10.750	11	10-1/8	13.688	10.482	.156	.134	78.32	13.624	10.420	.188	.165	94.16	13.250	10.020	.375	.365	154.00
14 x 12	14.000	12.750	11	10-5/8	13.688	12.438	.156	.156	80.10	13.624	12.390	.188	.180	96.30	13.250	12.000	.375	.375	157.00
16 x 6	16.000	6.625	12	10-3/8	15.670	6.407	.165	.109	96.60	15.624	6.357	.188	.134	109.00	15.250	6.065	.375	.280	184.00
16 x 8	16.000	8.625	12	10-3/4	15.670	8.407	.165	.109	97.75	15.624	8.329	.188	.148	110.00	15.250	7.981	.375	.322	187.00
16 x 10	16.000	10.750	12	11-1/8	15.670	10.482	.165	.134	98.90	15.624	10.420	.188	.165	112.00	15.250	10.020	.375	.365	189.00
16 x 12	16.000	12.750	12	11-5/8	15.670	12.438	.165	.156	101.00	15.624	12.390	.188	.180	114.00	15.250	12.000	.375	.375	193.00
16 x 14	16.000	14.000	12	12	15.670	13.688	.165	.156	103.00	15.624	13.624	.188	.188	117.00	15.250	13.250	.375	.375	198.00
18 x 8	18.000	8.625	13-1/2	11-3/4	17.670	8.407	.165	.109	125.00	17.624	8.329	.188	.148	142.00	17.250	7.981	.375	.322	240.00
18 x 10	18.000	10.750	13-1/2	12-1/8	17.670	10.482	.165	.134	126.00	17.624	10.420	.188	.165	143.00	17.250	10.020	.375	.365	243.00
18 x 12	18.000	12.750	13-1/2	12-5/8	17.670	12.438	.165	.156	128.00	17.624	12.390	.188	.180	145.00	17.250	12.000	.375	.375	246.00
18 x 14	18.000	14.000	13-1/2	13	17.670	13.688	.165	.156	131.00	17.624	13.624	.188	.188	148.00	17.250	13.250	.375	.375	251.00
18 x 16	18.000	16.000	13-1/2	13	17.670	15.670	.165	.165	134.00	17.624	15.624	.188	.188	152.00	17.250	15.250	.375	.375	257.00
20 x 8	20.000	8.625	15	12-3/4	19.624	8.407	.188	.109	141.00	19.564	8.329	.218	.148	189.00	19.250	7.981	.375	.322	297.00
20 x 10	20.000	10.750	15	13-1/8	19.624	10.482	.188	.134	143.00	19.564	10.420	.218	.165	191.00	19.250	10.020	.375	.365	300.00
20 x 12	20.000	12.750	15	13-5/8	19.624	12.438	.188	.156	145.00	19.564	12.390	.218	.180	193.00	19.250	12.000	.375	.375	304.00
20 x 14	20.000	14.000	15	14	19.624	13.688	.188	.156	147.00	19.564	13.624	.218	.188	196.00	19.250	13.250	.375	.375	308.00
20 x 16	20.000	16.000	15	14	19.624	15.670	.188	.165	150.00	19.564	15.624	.218	.188	200.00	19.250	15.250	.375	.375	315.00
20 x 18	20.000	18.000	15	14-1/2	19.624	17.670	.188	.165	154.00	19.564	17.624	.218	.188	205.00	19.250	17.250	.375	.375	322.00
24 x 10	24.000	10.750	17	15-1/8	23.564	10.482	.218	.134	247.00	23.500	10.420	.250	.165	284.00	23.250	10.020	.375	.365	413.00
24 x 12	24.000	12.750	17	15-5/8	23.564	12.438	.218	.156	250.00	23.500	12.390	.250	.180	288.00	23.250	12.000	.375	.375	418.00
24 x 14	24.000	14.000	17	16	23.564	13.688	.218	.156	253.00	23.500	13.624	.250	.188	291.00	23.250	13.250	.375	.375	423.00
24 x 16	24.000	16.000	17	16	23.564	15.670	.218	.165	256.00	23.500	15.624	.250	.188	295.00	23.250	15.250	.375	.375	428.00
24 x 18	24.000	18.000	17	16-1/2	23.564	17.670	.218	.165	262.00	23.500	17.624	.250	.188	302.00	23.250	17.250	.375	.375	438.00
24 x 20	24.000	20.000	17	17	23.564	19.624	.218	.188	268.00	23.500	19.564	.250	.218	308.00	23.250	19.250	.375	.375	448.00



REDUCING OUTLET TEES

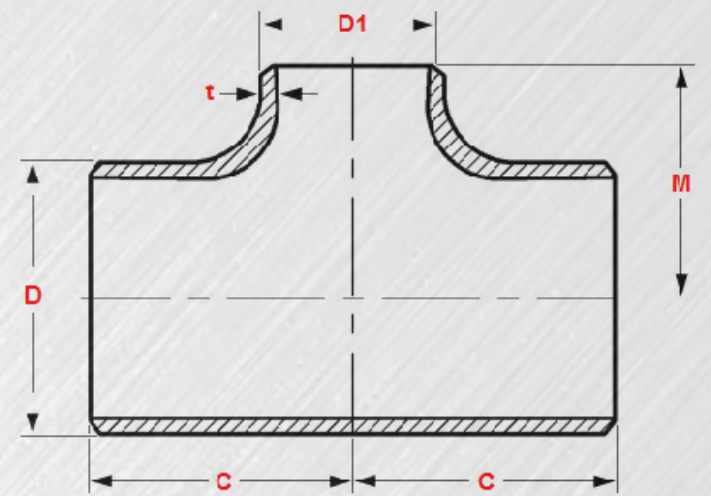

DIMENSIONS

Unit : inch / lb

Nominal Pipe Size Run X Outlet	Outside Diameter Run (O.D.)	Outside Diameter Outlet (O.D.)	Center to End Run (C)	Center to End Outlet (M)	Schedule 80S					Schedule 160S					XX Strong Wall					
					Inside Diameter Run (I.D.)	Inside Diameter Outlet (I.D.)	Wall thickness Run (T)	Wall thickness Outlet (T)	Approx. weight **	Inside Diameter Run (I.D.)	Inside Diameter Outlet (I.D.)	Wall thickness Run (T)	Wall thickness Outlet (T)	Approx. weight **	Inside Diameter Run (I.D.)	Inside Diameter Outlet (I.D.)	Wall thickness Run (T)	Wall thickness Outlet (T)	Approx. weight **	
1/2 x 1/4	.840	.540	1	1	.546	.302	.147	.119	.25	-----	-----	-----	-----	-----	-----	-----	-----	-----	-----	-----
1/2 x 3/8	.840	.675	1	1	.546	.423	.147	.126	.27	-----	-----	-----	-----	-----	-----	-----	-----	-----	-----	-----
3/4 x 3/8	1.050	.675	1-1/8	1-1/8	.742	.423	.154	.126	.38	.612	.301	.219	.187	.55	-----	-----	-----	-----	-----	-----
3/4 x 1/2	1.050	.840	1-1/8	1-1/8	.742	.546	.154	.147	.40	.612	.466	.219	.187	.57	.434	.252	.308	.294	.81	-----
1 x 3/8	1.315	.675	1-1/2	1-1/2	.957	.423	.179	.126	.73	.815	.301	.250	.187	1.02	-----	-----	-----	-----	-----	-----
1 x 1/2	1.315	.840	1-1/2	1-1/2	.957	.546	.179	.147	.75	.815	.466	.250	.187	1.04	.599	.252	.358	.294	1.49	-----
1 x 3/4	1.315	1.050	1-1/2	1-1/2	.957	.742	.179	.154	.76	.815	.614	.250	.218	1.07	.599	.434	.358	.308	1.53	-----
1-1/4 x 1/2	1.660	.840	1-7/8	1-7/8	1.278	.546	.191	.147	1.29	1.160	.466	.250	.187	1.69	.896	.252	.382	.294	2.58	-----
1-1/4 x 3/4	1.660	1.050	1-7/8	1-7/8	1.278	.742	.191	.154	1.32	1.160	.614	.250	.218	1.73	.896	.434	.382	.308	2.64	-----
1-1/4 x 1	1.660	1.315	1-7/8	1-7/8	1.278	.957	.191	.179	1.35	1.160	.815	.250	.250	1.77	.896	.599	.382	.358	2.70	-----
1-1/2 x 1/2	1.900	.840	2-1/4	2-1/4	1.500	.546	.200	.147	1.91	1.338	.466	.281	.187	2.67	1.100	.252	.400	.294	3.82	-----
1-1/2 x 3/4	1.900	1.050	2-1/4	2-1/4	1.500	.742	.200	.154	1.93	1.338	.614	.281	.218	2.71	1.100	.434	.400	.308	3.87	-----
1-1/2 x 1	1.900	1.315	2-1/4	2-1/4	1.500	.957	.200	.179	1.98	1.338	.815	.281	.250	2.77	1.100	.599	.400	.358	3.96	-----
1-1/2 x 1-1/4	1.900	1.660	2-1/4	2-1/4	1.500	1.278	.200	.191	2.02	1.338	1.160	.281	.250	2.83	1.100	.896	.400	.382	4.05	-----
2 x 3/4	2.375	1.050	2-1/2	1-3/4	1.939	.742	.218	.154	2.97	1.689	.614	.343	.218	4.67	1.503	.434	.436	.308	5.95	-----
2 x 1	2.375	1.315	2-1/2	2	1.939	.957	.218	.179	3.01	1.689	.815	.343	.250	4.73	1.503	.599	.436	.358	6.02	-----
2 x 1-1/4	2.375	1.660	2-1/2	2-1/4	1.939	1.278	.218	.191	3.08	1.689	1.160	.343	.250	4.84	1.503	.896	.436	.382	6.16	-----
2 x 1-1/2	2.375	1.900	2-1/2	2-3/8	1.939	1.500	.218	.200	3.15	1.689	1.338	.343	.281	4.95	1.503	1.100	.436	.400	6.30	-----
2-1/2 x 1	2.875	1.315	3	2-1/4	2.323	.957	.276	.179	5.86	2.125	.815	.375	.250	7.97	1.771	.599	.552	.358	11.73	-----
2-1/2 x 1-1/4	2.875	1.660	3	2-1/2	2.323	1.278	.276	.191	5.93	2.125	1.160	.375	.250	8.06	1.771	.896	.552	.382	11.87	-----
2-1/2 x 1-1/2	2.875	1.900	3	2-5/8	2.323	1.500	.276	.200	6.07	2.125	1.338	.375	.281	8.25	1.771	1.100	.552	.400	12.14	-----
2-1/2 x 2	2.875	2.375	3	2-3/4	2.323	1.939	.276	.218	6.21	2.125	1.689	.375	.343	8.44	1.771	1.503	.552	.436	12.42	-----
3 x 1	3.500	1.315	3-3/8	2-5/8	2.900	.957	.300	.179	8.23	2.624	.815	.438	.250	12.02	2.300	.599	.600	.358	16.46	-----
3 x 1-1/4	3.500	1.660	3-3/8	2-3/4	2.900	1.278	.300	.191	8.33	2.624	1.160	.438	.250	12.16	2.300	.896	.600	.382	16.66	-----
3 x 1-1/2	3.500	1.900	3-3/8	2-7/8	2.900	1.500	.300	.200	8.43	2.624	1.338	.438	.281	12.30	2.300	1.100	.600	.400	16.85	-----
3 x 2	3.500	2.375	3-3/8	3	2.900	1.939	.300	.218	8.62	2.624	1.689	.438	.343	12.59	2.300	1.503	.600	.436	17.24	-----
3 x 2-1/2	3.500	2.875	3-3/8	3-1/4	2.900	2.323	.300	.276	8.82	2.624	2.125	.438	.375	12.88	2.300	1.771	.600	.552	17.64	-----
3-1/2 x 1-1/2	4.000	1.900	3-3/4	3-1/8	3.364	1.500	.318	.200	10.20	-----	-----	-----	-----	-----	2.728	1.100	.636	.400	20.40	-----
3-1/2 x 2	4.000	2.375	3-3/4	3-1/4	3.364	1.939	.318	.218	10.32	-----	-----	-----	-----	-----	2.728	1.503	.636	.436	20.64	-----
3-1/2 x 2-1/2	4.000	2.875	3-3/4	3-1/2	3.364	2.323	.318	.276	10.56	-----	-----	-----	-----	-----	2.728	1.771	.636	.552	21.12	-----
3-1/2 x 3	4.000	3.500	3-3/4	3-5/8	3.364	2.900	.318	.300	10.80	-----	-----	-----	-----	-----	2.728	2.300	.636	.600	21.60	-----
4 x 1-1/2	4.500	1.900	4-1/8	3-3/8	3.826	1.500	.337	.200	14.28	3.438	1.338	.531	.281	22.56	3.152	1.100	.674	.400	28.56	-----
4 x 2	4.500	2.375	4-1/8	3-1/2	3.826	1.939	.337	.218	14.45	3.438	1.689	.531	.343	22.83	3.152	1.503	.674	.436	28.90	-----
4 x 2-1/2	4.500	2.875	4-1/8	3-3/4	3.826	2.323	.337	.276	14.62	3.438	2.125	.531	.375	23.10	3.152	1.771	.674	.552	29.24	-----
4 x 3	4.500	3.500	4-1/8	3-7/8	3.826	2.900	.337	.300	14.96	3.438	2.624	.531	.438	23.63	3.152	2.300	.674	.600	29.92	-----
4 x 3-1/2	4.500	4.000	4-1/8	4	3.826	3.364	.337	.318	15.30	-----	-----	-----	-----	-----	3.152	2.728	.674	.636	30.60	-----



REDUCING OUTLET TEES

DIMENSIONS

Unit : inch / lb

Nominal Pipe Size Run X Outlet	Outside Diameter Run (O.D)	Outside Diameter Outlet (O.D)	Center to End Run (C)	Center to End Outlet (M)	Schedule 80S					Schedule 160S					XX Strong Wall				
					Inside Diameter Run (I.D.)	Inside Diameter Outlet (I.D.)	Wall thickness Run (T)	Wall thickness Outlet (T)	Approx. weight **	Inside Diameter Run (I.D.)	Inside Diameter Outlet (I.D.)	Wall thickness Run (T)	Wall thickness Outlet (T)	Approx. weight **	Inside Diameter Run (I.D.)	Inside Diameter Outlet (I.D.)	Wall thickness Run (T)	Wall thickness Outlet (T)	Approx. weight **
5 x 2	5.563	2.375	4-7/8	4-1/8	4.813	1.939	.375	.218	21.00	4.313	1.689	.625	.343	35.07	4.063	1.503	.750	.436	42.00
5 x 2-1/2	5.563	2.875	4-7/8	4-1/4	4.813	2.323	.375	.276	21.25	4.313	2.125	.625	.375	35.48	4.063	1.771	.750	.552	42.50
5 x 3	5.563	3.500	4-7/8	4-3/8	4.813	2.900	.375	.300	21.50	4.313	2.624	.625	.438	35.90	4.063	2.300	.750	.600	43.00
5 x 3-1/2	5.563	4.000	4-7/8	4-1/2	4.813	3.364	.375	.318	22.00	-----	-----	-----	-----	-----	4.063	2.728	.750	.636	44.00
5 x 4	5.563	4.500	4-7/8	4-5/8	4.813	3.826	.375	.337	22.50	4.313	3.438	.625	.531	37.57	4.063	3.152	.750	.674	45.00
6 x 2-1/2	6.625	2.875	5-5/8	4-3/4	5.761	2.323	.432	.276	25.20	5.187	2.125	.719	.375	41.83	4.897	1.771	.864	.552	50.40
6 x 3	6.625	3.500	5-5/8	4-7/8	5.761	2.900	.432	.300	25.50	5.187	2.624	.719	.438	42.33	4.897	2.300	.864	.600	51.00
6 x 3-1/2	6.625	4.000	5-5/8	5	5.761	3.364	.432	.318	25.80	-----	-----	-----	-----	-----	4.897	2.728	.864	.636	51.60
6 x 4	6.625	4.500	5-5/8	5-1/8	5.761	3.826	.432	.337	26.40	5.187	3.438	.719	.531	43.82	4.897	3.152	.864	.674	52.80
6 x 5	6.625	5.563	5-5/8	5-3/8	5.761	4.813	.432	.375	27.00	5.187	4.313	.719	.625	44.82	4.897	4.063	.864	.750	54.00
8 x 3	8.625	3.500	7	6	7.625	2.900	.500	.300	52.08	6.813	2.624	.906	.438	94.00	6.875	2.300	.875	.600	90.70
8 x 3-1/2	8.625	4.000	7	6	7.625	3.364	.500	.318	52.70	-----	-----	-----	-----	-----	6.875	2.728	.875	.636	91.80
8 x 4	8.625	4.500	7	6-1/8	7.625	3.826	.500	.337	53.32	6.813	3.438	.906	.531	96.30	6.875	3.152	.875	.674	92.90
8 x 5	8.625	5.563	7	6-3/8	7.625	4.813	.500	.375	54.56	6.813	4.313	.906	.625	98.50	6.875	4.063	.875	.750	95.00
8 x 6	8.625	6.625	7	6-5/8	7.625	5.761	.500	.432	55.80	6.813	5.187	.906	.719	101.00	6.875	4.897	.875	.864	97.20
10 x 4	10.750	4.500	8-1/2	7-1/4	9.750	3.826	.500	.337	93.50	8.500	3.438	1.125	.531	210.00	-----	-----	-----	-----	-----
10 x 5	10.750	5.563	8-1/2	7-1/2	9.750	4.813	.500	.375	94.60	8.500	4.313	1.125	.625	212.00	-----	-----	-----	-----	-----
10 x 6	10.750	6.625	8-1/2	7-5/8	9.750	5.761	.500	.432	96.80	8.500	5.187	1.125	.719	217.00	-----	-----	-----	-----	-----
10 x 8	10.750	8.625	8-1/2	8	9.750	7.625	.500	.500	99.00	8.500	6.813	1.125	.906	222.00	-----	-----	-----	-----	-----
12 x 5	12.750	5.563	10	8-1/2	11.750	4.813	.500	.375	157.00	10.126	4.313	1.312	.625	411.00	-----	-----	-----	-----	-----
12 x 6	12.750	6.625	10	8-5/8	11.750	5.761	.500	.432	159.00	10.126	5.187	1.312	.719	416.00	-----	-----	-----	-----	-----
12 x 8	12.750	8.625	10	9	11.750	7.625	.500	.500	163.00	10.126	6.813	1.312	.906	426.00	-----	-----	-----	-----	-----
12 x 10	12.750	10.750	10	9-1/2	11.750	9.750	.500	.500	166.00	10.126	8.500	1.312	1.125	435.00	-----	-----	-----	-----	-----
14 x 6	14.000	6.625	11	9-3/8	13.000	5.761	.500	.432	178.00	11.188	5.187	1.406	.719	-----	-----	-----	-----	-----	-----
14 x 8	14.000	8.625	11	9-3/4	13.000	7.625	.500	.500	180.00	11.188	6.813	1.406	.906	-----	-----	-----	-----	-----	-----
14 x 10	14.000	10.750	11	10-1/8	13.000	9.750	.500	.500	185.00	11.188	8.500	1.406	1.125	-----	-----	-----	-----	-----	-----
14 x 12	14.000	12.750	11	10-5/8	13.000	11.750	.500	.500	189.00	11.188	10.126	1.406	1.312	-----	-----	-----	-----	-----	-----
16 x 6	16.000	6.625	12	10-3/8	15.000	5.761	.500	.432	222.00	12.812	5.187	1.594	.719	-----	-----	-----	-----	-----	-----
16 x 8	16.000	8.625	12	10-3/4	15.000	7.625	.500	.500	225.00	12.812	6.813	1.594	.906	-----	-----	-----	-----	-----	-----
16 x 10	16.000	10.750	12	11-1/8	15.000	9.750	.500	.500	228.00	12.812	8.500	1.594	1.125	-----	-----	-----	-----	-----	-----
16 x 12	16.000	12.750	12	11-5/8	15.000	11.750	.500	.500	233.00	12.812	10.126	1.594	1.312	-----	-----	-----	-----	-----	-----
16 x 14	16.000	14.000	12	12	15.000	13.000	.500	.500	238.00	12.812	11.188	1.594	1.406	-----	-----	-----	-----	-----	-----
18 x 8	18.000	8.625	13-1/2	11-3/4	17.000	7.625	.500	.500	289.00	14.438	6.813	1.781	.906	-----	-----	-----	-----	-----	-----
18 x 10	18.000	10.750	13-1/2	12-1/8	17.000	9.750	.500	.500	292.00	14.438	8.500	1.781	1.125	-----	-----	-----	-----	-----	-----
18 x 12	18.000	12.750	13-1/2	12-5/8	17.000	11.750	.500	.500	296.00	14.438	10.126	1.781	1.312	-----	-----	-----	-----	-----	-----
18 x 14	18.000	14.000	13-1/2	13	17.000	13.000	.500	.500	303.00	14.438	11.188	1.781	1.406	-----	-----	-----	-----	-----	-----
18 x 16	18.000	16.000	13-1/2	13	17.000	15.000	.500	.500	309.00	14.438	12.812	1.781	1.594	-----	-----	-----	-----	-----	-----
20 x 8	20.000	8.625	15	12-3/4	19.000	7.625	.500	.500	357.00	16.062	6.813	1.969	.906	-----	-----	-----	-----	-----	-----
20 x 10	20.000	10.750	15	13-1/8	19.000	9.750	.500	.500	361.00	16.062	8.500	1.969	1.125	-----	-----	-----	-----	-----	-----
20 x 12	20.000	12.750	15	13-5/8	19.000	11.750	.500	.500	365.00	16.062	10.126	1.969	1.312	-----	-----	-----	-----	-----	-----
20 x 14	20.000	14.000	15	14	19.000	13.000	.500	.500	370.00	16.062	11.188	1.969	1.406	-----	-----	-----	-----	-----	-----
20 x 16	20.000	16.000	15	14	19.000	15.000	.500	.500	378.00	16.062	12.812	1.969	1.594	-----	-----	-----	-----	-----	-----
20 x 18	20.000	18.000	15	14-1/2	19.000	17.000	.500	.500	387.00	16.062	14.438	1.969	1.781	-----	-----	-----	-----	-----	-----
24 x 10	24.000	10.750	17	15-1/8	23.000	9.750	.500	.500	498.00	19.312	8.500	2.344	1.125	-----	-----	-----	-----	-----	-----
24 x 12	24.000	12.750	17	15-5/8	23.000	11.750	.500	.500	504.00	19.312	10.126	2.344	1.312	-----	-----	-----	-----	-----	-----
24 x 14	24.000	14.000	17	16	23.000	13.000	.500	.500	510.00	19.312	11.188	2.344	1.406	-----	-----	-----	-----	-----	-----
24 x 16	24.000	16.000	17	16	23.000	15.000	.500	.500	516.00	19.312	12.812	2.344	1.594	-----	-----	-----	-----	-----	-----
24 x 18	24.000	18.000	17	16-1/2	23.000	17.000	.500	.500	528.00	19.312	14.438	2.344	1.781	-----	-----	-----	-----	-----	-----
24 x 20	24.000	20.000	17	17	23.000	19.000	.500	.500	540.00	19.312	16.062	2.344	1.969	-----	-----	-----	-----	-----	-----



CONCENTRIC / ECCENTRIC REDUCERS

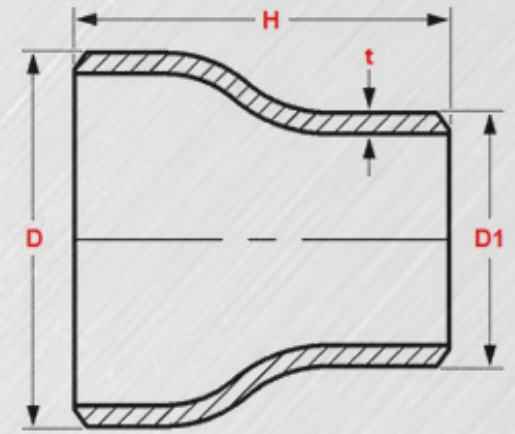

Reducer concentric

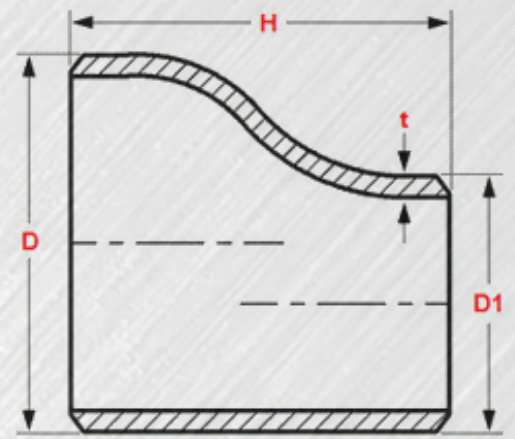

Reducer eccentric

DIMENSIONS

Unit : inch / lb

Nominal Pipe Size Large End X Small End	Outside Diameter Large End (O.D)	Outside Diameter Small End (O.D)	Length (H)	Schedule 5S					Schedule 10S					Schedule 40S				
				Inside Diameter Large End (I.D.)	Inside Diameter Small End (I.D.)	Wall thickness Large End (T)	Wall thickness Small End (T)	Approx. weight **	Inside Diameter Large End (I.D.)	Inside Diameter Small End (I.D.)	Wall thickness Large End (T)	Wall thickness Small End (T)	Approx. weight **	Inside Diameter Large End (I.D.)	Inside Diameter Small End (I.D.)	Wall thickness Large End (T)	Wall thickness Small End (T)	Approx. weight **
3/4x 3/8	1.050	.675	1-1/2	.920	.545	.065	.065	.15	.884	.545	.083	.065	.20	.824	.493	.113	.091	.27
3/4x 1/2	1.050	.840	1-1/2	.920	.710	.065	.065	.17	.884	.674	.083	.083	.22	.824	.622	.113	.109	.31
1x 3/8	1.315	.675	2	1.185	.545	.065	.065	.16	1.097	.545	.109	.065	.21	1.049	.493	.133	.091	.33
1x 1/2	1.315	.840	2	1.185	.710	.065	.065	.16	1.097	.674	.109	.083	.27	1.049	.622	.133	.109	.34
1x 3/4	1.315	1.050	2	1.185	.920	.065	.065	.17	1.097	.884	.109	.083	.29	1.049	.824	.133	.113	.36
1-1/4 x 1/2	1.660	.840	2	1.530	.710	.065	.065	.21	1.442	.674	.109	.083	.35	1.380	.622	.140	.109	.46
1-1/4 x 3/4	1.660	1.050	2	1.530	.920	.065	.065	.22	1.442	.884	.109	.083	.39	1.380	.824	.140	.113	.49
1-1/4 x 1	1.660	1.315	2	1.530	1.185	.065	.065	.22	1.442	1.097	.109	.109	.39	1.380	1.049	.140	.133	.49
1-1/2 x 1/2	1.900	.840	2-1/2	1.770	.710	.065	.065	.23	1.682	.674	.109	.083	.37	1.610	.622	.145	.109	.50
1-1/2 x 3/4	1.900	1.050	2-1/2	1.770	.920	.065	.065	.24	1.682	.884	.109	.083	.39	1.610	.824	.145	.113	.52
1-1/2 x 1	1.900	1.315	2-1/2	1.770	1.185	.065	.065	.25	1.682	1.097	.109	.109	.43	1.610	1.049	.145	.133	.58
1-1/2 x 1-1/4	1.900	1.660	2-1/2	1.770	1.530	.065	.065	.27	1.682	1.442	.109	.109	.46	1.610	1.380	.145	.140	.62
2x 3/4	2.375	1.050	3	2.245	.920	.065	.065	.33	2.157	.884	.109	.083	.56	2.067	.824	.154	.113	.80
2x 1	2.375	1.315	3	2.245	1.185	.065	.065	.37	2.157	1.097	.109	.109	.62	2.067	1.049	.154	.133	.89
2x 1-1/4	2.375	1.660	3	2.245	1.530	.065	.065	.40	2.157	1.442	.109	.109	.67	2.067	1.380	.154	.140	.96
2x 1-1/2	2.375	1.900	3	2.245	1.770	.065	.065	.41	2.157	1.682	.109	.109	.69	2.067	1.610	.154	.145	.99
2-1/2 x 1	2.875	1.315	3-1/2	2.709	1.185	.083	.065	.56	2.635	1.097	.120	.109	.83	2.469	1.049	.203	.133	1.42
2-1/2 x 1-1/4	2.875	1.660	3-1/2	2.709	1.530	.083	.065	.64	2.635	1.442	.120	.109	.95	2.469	1.380	.203	.140	1.61
2-1/2 x 1-1/2	2.875	1.900	3-1/2	2.709	1.770	.083	.065	.67	2.635	1.682	.120	.109	.98	2.469	1.610	.203	.145	1.67
2-1/2 x 2	2.875	2.375	3-1/2	2.709	2.245	.083	.065	.70	2.635	2.157	.120	.109	1.03	2.469	2.067	.203	.154	1.76
3x 1	3.500	1.315	3-1/2	3.334	1.185	.083	.065	.70	3.260	1.097	.120	.109	1.03	3.068	1.049	.216	.133	1.81
3x 1-1/4	3.500	1.660	3-1/2	3.334	1.530	.083	.065	.70	3.260	1.442	.120	.109	1.03	3.068	1.380	.216	.140	1.86
3x 1-1/2	3.500	1.900	3-1/2	3.334	1.770	.083	.065	.78	3.260	1.682	.120	.109	1.13	3.068	1.610	.216	.145	2.07
3x 2	3.500	2.375	3-1/2	3.334	2.245	.083	.065	.83	3.260	2.157	.120	.109	1.21	3.068	2.067	.216	.154	2.20
3x 2-1/2	3.500	2.875	3-1/2	3.334	2.709	.083	.083	.90	3.260	2.635	.120	.120	1.30	3.068	2.469	.216	.203	2.38
3-1/2 x 1-1/4	4.000	1.660	4	3.834	1.530	.083	.065	.93	3.760	1.442	.120	.109	1.37	3.548	1.380	.226	.140	2.60
3-1/2 x 1-1/2	4.000	1.900	4	3.834	1.770	.083	.065	.99	3.760	1.682	.120	.109	1.46	3.548	1.610	.226	.145	2.76
3-1/2 x 2	4.000	2.375	4	3.834	2.245	.083	.065	1.06	3.760	2.157	.120	.109	1.57	3.548	2.067	.226	.154	2.97
3-1/2 x 2-1/2	4.000	2.875	4	3.834	2.709	.083	.083	1.17	3.760	2.635	.120	.120	1.72	3.548	2.469	.226	.203	3.25
3-1/2 x 3	4.000	3.500	4	3.834	3.334	.083	.083	1.20	3.760	3.260	.120	.120	1.77	3.548	3.068	.226	.216	3.35
4x 1-1/2	4.500	1.900	4	4.334	1.770	.083	.065	1.05	4.260	1.682	.120	.109	1.50	4.026	1.610	.237	.145	3.00
4x 2	4.500	2.375	4	4.334	2.245	.083	.065	1.21	4.260	2.157	.120	.109	1.73	4.026	2.067	.237	.154	3.47
4x 2-1/2	4.500	2.875	4	4.334	2.709	.083	.083	1.28	4.260	2.635	.120	.120	1.83	4.026	2.469	.237	.203	3.66
4x 3	4.500	3.500	4	4.334	3.334	.083	.083	1.34	4.260	3.260	.120	.120	1.92	4.026	3.068	.237	.216	3.84
4x 3-1/2	4.500	4.000	4	4.334	3.834	.083	.083	1.38	4.260	3.760	.120	.120	1.98	4.026	3.548	.237	.226	3.97



CONCENTRIC / ECCENTRIC REDUCERS

DIMENSIONS

Unit : inch / lb

Nominal Pipe Size <small>Large End X Small End</small>	Outside Diameter Large End (O.D.)	Outside Diameter Small End (O.D.)	Length (H)	Schedule 5S					Schedule 10S					Schedule 40S				
				Inside Diameter Large End (I.D.)	Inside Diameter Small End (I.D.)	Wall thickness Large End (T)	Wall thickness Small End (T)	Approx. weight **	Inside Diameter Large End (I.D.)	Inside Diameter Small End (I.D.)	Wall thickness Large End (T)	Wall thickness Small End (T)	Approx. weight **	Inside Diameter Large End (I.D.)	Inside Diameter Small End (I.D.)	Wall thickness Large End (T)	Wall thickness Small End (T)	Approx. weight **
5 x 2	5.563	2.375	5	5.345	2.245	.109	.065	2.33	5.295	2.157	.134	.109	2.83	5.047	2.067	.258	.154	5.55
5 x 2-1/2	5.563	2.875	5	5.345	2.709	.109	.083	2.55	5.295	2.635	.134	.120	3.09	5.047	2.469	.258	.203	6.07
5x3	5.563	3.500	5	5.345	3.334	.109	.083	2.64	5.295	3.260	.134	.120	3.20	5.047	3.068	.258	.216	6.29
5x3-1/2	5.563	4.000	5	5.345	3.834	.109	.083	2.71	5.295	3.760	.134	.120	3.28	5.047	3.548	.258	.226	6.45
5x 4	5.563	4.500	5	5.345	4.334	.109	.083	2.76	5.295	4.260	.134	.120	3.29	5.047	4.026	.258	.237	6.57
6x2-1/2	6.625	2.875	5-1/2	6.407	2.709	.109	.083	3.18	6.357	2.635	.134	.120	3.35	6.065	2.469	.280	.203	8.37
6x3	6.625	3.500	5-1/2	6.407	3.334	.109	.083	3.33	6.357	3.260	.134	.120	4.01	6.065	3.068	.280	.216	8.77
6x3-1/2	6.625	4.000	5-1/2	6.407	3.834	.109	.083	3.39	6.357	3.760	.134	.120	4.20	6.065	3.548	.280	.226	8.93
6x 4	6.625	4.500	5-1/2	6.407	4.334	.109	.083	3.41	6.357	4.260	.134	.120	4.31	6.065	4.026	.280	.237	8.99
6x 5	6.625	5.563	5-1/2	6.407	5.345	.109	.109	3.60	6.357	5.295	.134	.134	4.45	6.065	5.047	.280	.258	9.48
8 x3-1/2	8.625	4.000	6	8.407	3.834	.109	.083	4.65	8.329	3.760	.148	.120	6.48	7.981	3.548	.322	.226	14.10
8x 4	8.625	4.500	6	8.407	4.334	.109	.083	4.76	8.329	4.260	.148	.120	6.64	7.981	4.026	.322	.237	14.44
8x5	8.625	5.563	6	8.407	5.345	.109	.109	4.87	8.329	5.295	.148	.134	6.79	7.981	5.047	.322	.258	14.78
8x6	8.625	6.625	6	8.407	6.407	.109	.109	5.05	8.329	6.357	.148	.134	7.04	7.981	6.065	.322	.280	15.31
10x 4	10.750	4.500	7	10.482	4.334	.134	.083	8.34	10.420	4.260	.165	.120	10.43	10.020	4.026	.365	.237	23.19
10x5	10.750	5.563	7	10.482	5.345	.134	.109	8.62	10.420	5.295	.165	.134	10.78	10.020	5.047	.365	.258	23.96
10x6	10.750	6.625	7	10.482	6.407	.134	.109	8.82	10.420	6.357	.165	.134	11.03	10.020	6.065	.365	.280	24.52
10x8	10.750	8.625	7	10.482	8.407	.134	.109	9.17	10.420	8.329	.165	.148	11.46	10.020	7.981	.365	.322	25.48
12x5	12.750	5.563	8	12.438	5.345	.156	.109	13.72	12.390	5.295	.180	.134	16.07	12.000	5.047	.375	.258	33.48
12x6	12.750	6.625	8	12.438	6.407	.156	.109	14.01	12.390	6.357	.180	.134	16.38	12.000	6.065	.375	.280	34.13
12x8	12.750	8.625	8	12.438	8.407	.156	.109	14.45	12.390	8.329	.180	.148	16.91	12.000	7.981	.375	.322	35.24
12x10	12.750	10.750	8	12.438	10.482	.156	.134	15.03	12.390	10.420	.180	.165	17.60	12.000	10.020	.375	.365	36.67
14x6	14.000	6.625	13	13.688	6.407	.156	.109	23.78	13.624	6.357	.188	.134	29.00	13.250	6.065	.375	.280	58.00
14x8	14.000	8.625	13	13.688	8.407	.156	.109	25.10	13.624	8.329	.188	.148	30.61	13.250	7.981	.375	.322	61.22
14x10	14.000	10.750	13	13.688	10.482	.156	.134	26.05	13.624	10.420	.188	.165	31.77	13.250	10.020	.375	.365	63.55
14x12	14.000	12.750	13	13.688	12.438	.156	.156	27.64	13.624	12.390	.188	.180	33.71	13.250	12.000	.375	.375	67.42
16x8	16.000	8.625	14	15.670	8.407	.165	.109	32.39	15.624	8.329	.188	.148	36.81	15.250	7.981	.375	.322	73.62
16x10	16.000	10.750	14	15.670	10.482	.165	.134	34.37	15.624	10.420	.188	.165	39.06	15.250	10.020	.375	.365	78.12
16x12	16.000	12.750	14	15.670	12.438	.165	.156	35.60	15.624	12.390	.188	.180	40.45	15.250	12.000	.375	.375	80.91
16x14	16.000	14.000	14	15.670	13.688	.165	.156	36.48	15.624	13.624	.188	.188	41.46	15.250	13.250	.375	.375	82.92
18x10	18.000	10.750	15	17.670	10.482	.165	.134	40.78	17.624	10.420	.188	.165	46.34	17.250	10.020	.375	.365	92.69
18x12	18.000	12.750	15	17.670	12.438	.165	.156	41.66	17.624	12.390	.188	.180	47.35	17.250	12.000	.375	.375	94.70
18x14	18.000	14.000	15	17.670	13.688	.165	.156	42.48	17.624	13.624	.188	.188	48.28	17.250	13.250	.375	.375	96.56
18x16	18.000	16.000	15	17.670	15.670	.165	.165	43.64	17.624	15.624	.188	.188	49.60	17.250	15.250	.375	.375	99.20
20x12	20.000	12.750	20	19.624	12.438	.188	.156	71.50	19.564	12.390	.218	.180	71.50	19.250	12.000	.375	.375	143.00
20x14	20.000	14.000	20	19.624	13.688	.188	.156	72.50	19.564	13.624	.218	.188	84.10	19.250	13.250	.375	.375	145.00
20x16	20.000	16.000	20	19.624	15.670	.188	.165	73.00	19.564	15.624	.218	.188	84.68	19.250	15.250	.375	.375	146.00
20x18	20.000	18.000	20	19.624	17.670	.188	.165	75.50	19.564	17.624	.218	.188	87.58	19.250	17.250	.375	.375	151.00
24x16	24.000	16.000	20	23.564	15.670	.218	.165	98.02	23.500	15.624	.250	.188	98.02	23.250	15.250	.375	.375	169.00
24x18	24.000	18.000	20	23.564	17.670	.218	.165	100.00	23.500	17.624	.250	.188	100.00	23.250	17.250	.375	.375	173.00
24x20	24.000	20.000	20	23.564	19.624	.218	.188	103.00	23.500	19.564	.250	.218	103.00	23.250	19.250	.375	.375	179.00



CONCENTRIC / ECCENTRIC REDUCERS

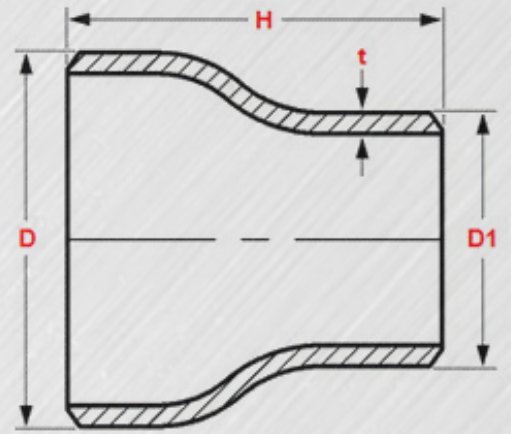

Reducer concentric

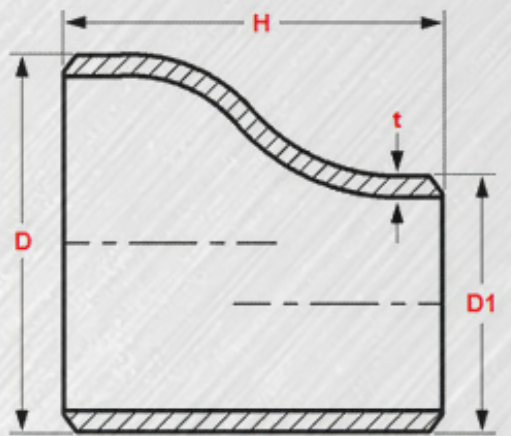

Reducer eccentric

DIMENSIONS

Unit : inch / lb

Nominal Pipe Size <small>Large End X Small End</small>	Outside Diameter Large End (O.D.)	Outside Diameter Small End (O.D.)	Length (H)	Schedule 80S					Schedule 160S					XX Strong Wall						
				Inside Diameter Large End (I.D.)	Inside Diameter Small End (I.D.)	Wall thickness Large End (T)	Wall thickness Small End (T)	Approx. weight **	Inside Diameter Large End (I.D.)	Inside Diameter Small End (I.D.)	Wall thickness Large End (T)	Wall thickness Small End (T)	Approx. weight **	Inside Diameter Large End (I.D.)	Inside Diameter Small End (I.D.)	Wall thickness Large End (T)	Wall thickness Small End (T)	Approx. weight **		
3/4x3/8	1.050	.675	1-1/2	.742	.423	.154	.126	.37	-----	-----	-----	-----	-----	-----	-----	-----	-----	-----	-----	-----
3/4x1/2	1.050	.840	1-1/2	.742	.546	.154	.147	.40	.612	.466	.219	.187	.55	.434	.252	.308	.294	.80		
1x3/8	1.315	.675	2	.957	.423	.179	.126	.42	-----	-----	-----	-----	-----	-----	-----	-----	-----	-----	-----	-----
1x1/2	1.315	.840	2	.957	.546	.179	.147	.44	.815	.466	.250	.187	.57	.599	.252	.358	.294	.88		
1x3/4	1.315	1.050	2	.957	.742	.179	.154	.49	.815	.612	.250	.219	.61	.599	.434	.358	.308	.98		
1-1/4 x 1/2	1.660	.840	2	1.278	.546	.191	.147	.52	1.160	.466	.250	.187	.67	.896	.252	.382	.294	1.04		
1-1/4 x 3/4	1.660	1.050	2	1.278	.742	.191	.154	.56	1.160	.612	.250	.219	.73	.896	.434	.382	.308	1.12		
1-1/4 x 1	1.660	1.315	2	1.278	.957	.191	.179	.59	1.160	.815	.250	.250	.82	.896	.599	.382	.358	1.18		
1-1/2 x 1/2	1.900	.840	2-1/2	1.500	.546	.200	.147	.68	1.338	.466	.281	.187	.95	1.100	.252	.400	.294	1.36		
1-1/2 x 3/4	1.900	1.050	2-1/2	1.500	.742	.200	.154	.71	1.338	.612	.281	.219	.99	1.100	.434	.400	.308	1.42		
1-1/2 x 1	1.900	1.315	2-1/2	1.500	.957	.200	.179	.74	1.338	.815	.281	.250	1.03	1.100	.599	.400	.358	1.48		
1-1/2 x 1-1/4	1.900	1.660	2-1/2	1.500	1.278	.200	.191	.80	1.338	1.160	.281	.250	1.12	1.100	.896	.400	.382	1.60		
2x 3/4	2.375	1.050	3	1.939	.742	.218	.154	1.11	1.689	.612	.343	.219	1.74	1.503	.434	.436	.308	2.22		
2x 1	2.375	1.315	3	1.939	.957	.218	.179	1.18	1.689	.815	.343	.250	1.85	1.503	.599	.436	.358	2.36		
2x 1-1/4	2.375	1.660	3	1.939	1.278	.218	.191	1.27	1.689	1.160	.343	.250	1.99	1.503	.896	.436	.382	2.54		
2x 1-1/2	2.375	1.900	3	1.939	1.500	.218	.200	1.30	1.689	1.338	.343	.281	2.04	1.503	1.100	.436	.400	2.60		
2-1/2 x 1	2.875	1.315	3-1/2	2.323	.957	.276	.179	1.92	2.125	.815	.375	.250	2.59	1.771	.599	.552	.358	3.84		
2-1/2 x 1-1/4	2.875	1.660	3-1/2	2.323	1.278	.276	.191	1.98	2.125	1.160	.375	.250	2.67	1.771	.896	.552	.382	3.96		
2-1/2 x 1-1/2	2.875	1.900	3-1/2	2.323	1.500	.276	.200	2.07	2.125	1.338	.375	.281	2.79	1.771	1.100	.552	.400	4.14		
2-1/2 x 2	2.875	2.375	3-1/2	2.323	1.939	.276	.218	2.26	2.125	1.689	.375	.343	3.05	1.771	1.503	.552	.436	4.52		
3x 1	3.500	1.315	3-1/2	2.900	.957	.300	.179	2.39	2.624	.815	.438	.250	3.32	2.300	.599	.600	.358	4.76		
3x 1-1/4	3.500	1.660	3-1/2	2.900	1.278	.300	.191	2.51	2.624	1.160	.438	.250	3.63	2.300	.896	.600	.382	5.02		
3x 1-1/2	3.500	1.900	3-1/2	2.900	1.500	.300	.200	2.66	2.624	1.338	.438	.281	3.85	2.300	1.100	.600	.400	5.32		
3x 2	3.500	2.375	3-1/2	2.900	1.939	.300	.218	2.85	2.624	1.689	.438	.343	4.13	2.300	1.503	.600	.436	5.70		
3x 2-1/2	3.500	2.875	3-1/2	2.900	2.323	.300	.276	3.28	2.624	2.125	.438	.375	4.75	2.300	1.771	.600	.552	6.56		
3-1/2 x 1-1/4	4.000	1.660	4	3.364	1.278	.318	.191	3.53	-----	-----	-----	-----	-----	2.728	.896	.636	.382	7.06		
3-1/2 x 1-1/2	4.000	1.900	4	3.364	1.500	.318	.200	3.69	-----	-----	-----	-----	-----	2.728	1.100	.636	.400	7.38		
3-1/2 x 2	4.000	2.375	4	3.364	1.939	.318	.218	3.87	-----	-----	-----	-----	-----	2.728	1.503	.636	.436	7.74		
3-1/2 x 2-1/2	4.000	2.875	4	3.364	2.323	.318	.276	4.21	-----	-----	-----	-----	-----	2.728	1.771	.636	.552	8.42		
3-1/2 x 3	4.000	3.500	4	3.364	2.900	.318	.300	4.46	-----	-----	-----	-----	-----	2.728	2.300	.636	.600	8.92		
4x 1-1/2	4.500	1.900	4	3.826	1.500	.337	.200	4.18	3.438	1.338	.531	.281	6.56	3.152	1.100	.674	.400	8.36		
4x 2	4.500	2.375	4	3.826	1.939	.337	.218	4.31	3.438	1.689	.531	.343	6.76	3.152	1.503	.674	.436	8.62		
4x 2-1/2	4.500	2.875	4	3.826	2.323	.337	.276	4.83	3.438	2.125	.531	.375	7.58	3.152	1.771	.674	.552	9.66		
4x 3	4.500	3.500	4	3.826	2.900	.337	.300	5.14	3.438	2.624	.531	.438	8.07	3.152	2.300	.674	.600	10.28		
4x 3-1/2	4.500	4.000	4	3.826	3.364	.337	.318	5.33	-----	-----	-----	-----	-----	3.152	2.728	.674	.636	10.66		



CONCENTRIC / ECCENTRIC REDUCERS

DIMENSIONS

Unit : inch / lb

Nominal Pipe Size <small>Large End X Small End</small>	Outside Diameter Large End (O.D)	Outside Diameter Small End (O.D)	Length (H)	Schedule 80S					Schedule 160S					XX Strong Wall				
				Inside Diameter Large End (I.D.)	Inside Diameter Small End (I.D.)	Wall thickness Large End (T)	Wall thickness Small End (T)	Approx. weight **	Inside Diameter Large End (I.D.)	Inside Diameter Small End (I.D.)	Wall thickness Large End (T)	Wall thickness Small End (T)	Approx. weight **	Inside Diameter Large End (I.D.)	Inside Diameter Small End (I.D.)	Wall thickness Large End (T)	Wall thickness Small End (T)	Approx. weight **
5 x 2	5.563	2.375	5	4.813	1.939	.375	.218	7.25	4.313	1.689	.625	.343	12.03	4.063	1.503	.750	.436	14.50
5 x 2-1/2	5.563	2.875	5	4.813	2.323	.375	.276	7.93	4.313	2.125	.625	.375	13.16	4.063	1.771	.750	.552	15.86
5x3	5.563	3.500	5	4.813	2.900	.375	.300	8.55	4.313	2.624	.625	.438	14.19	4.063	2.300	.750	.600	17.10
5x3-1/2	5.563	4.000	5	4.813	3.364	.375	.318	8.80	-----	-----	-----	-----	-----	4.063	2.728	.750	.636	17.60
5x4	5.563	4.500	5	4.813	3.826	.375	.337	9.11	4.313	3.438	.625	.531	15.12	4.063	3.152	.750	.674	18.22
6x2-1/2	6.625	2.875	5-1/2	5.761	2.323	.432	.276	10.88	5.187	2.125	.719	.375	18.06	4.897	1.771	.864	.552	21.76
6x3	6.625	3.500	5-1/2	5.761	2.900	.432	.300	12.15	5.187	2.624	.719	.438	20.17	4.897	2.300	.864	.600	24.30
6x3-1/2	6.625	4.000	5-1/2	5.761	3.364	.432	.318	12.67	-----	-----	-----	-----	-----	4.897	2.728	.864	.636	25.34
6x4	6.625	4.500	5-1/2	5.761	3.826	.432	.337	13.14	5.187	3.438	.719	.531	21.81	4.897	3.152	.864	.674	26.28
6x5	6.625	5.563	5-1/2	5.761	4.813	.432	.375	13.79	5.187	4.313	.719	.625	22.89	4.897	4.063	.864	.750	27.58
8 x3-1/2	8.625	4.000	6	7.625	3.364	.500	.318	17.61	-----	-----	-----	-----	-----	6.875	2.728	.875	.636	30.81
8x4	8.625	4.500	6	7.625	3.826	.500	.337	20.36	6.813	3.438	.906	.531	36.85	6.875	3.152	.875	.674	35.63
8x5	8.625	5.563	6	7.625	4.813	.500	.375	21.32	6.813	4.313	.906	.625	38.50	6.875	4.063	.875	.750	37.31
8x6	8.625	6.625	6	7.625	5.761	.500	.432	22.32	6.813	5.187	.906	.719	40.30	6.875	4.897	.875	.864	39.06
10x4	10.750	4.500	7	9.750	3.826	.500	.337	27.68	8.500	3.438	1.125	.531	62.30	-----	-----	-----	-----	-----
10x5	10.750	5.563	7	9.750	4.813	.500	.375	31.40	8.500	4.313	1.125	.625	70.60	-----	-----	-----	-----	-----
10x6	10.750	6.625	7	9.750	5.761	.500	.432	32.61	8.500	5.187	1.125	.719	73.30	-----	-----	-----	-----	-----
10x8	10.750	8.625	7	9.750	7.625	.500	.500	34.34	8.500	6.813	1.125	.906	77.10	-----	-----	-----	-----	-----
12x5	12.750	5.563	8	11.750	4.813	.500	.375	42.78	10.126	4.313	1.312	.625	112.00	-----	-----	-----	-----	-----
12x6	12.750	6.625	8	11.750	5.761	.500	.432	44.42	10.126	5.187	1.312	.719	116.00	-----	-----	-----	-----	-----
12x8	12.750	8.625	8	11.750	7.625	.500	.500	46.06	10.126	6.813	1.312	.906	120.00	-----	-----	-----	-----	-----
12x10	12.750	10.750	8	11.750	9.750	.500	.500	47.70	10.126	8.500	1.312	1.125	124.00	-----	-----	-----	-----	-----
14x6	14.000	6.625	13	13.000	5.761	.500	.432	77.81	11.188	5.187	1.406	.719	-----	-----	-----	-----	-----	-----
14x8	14.000	8.625	13	13.000	7.625	.500	.500	81.22	11.188	6.813	1.406	.906	-----	-----	-----	-----	-----	-----
14x10	14.000	10.750	13	13.000	9.750	.500	.500	85.40	11.188	8.500	1.406	1.125	-----	-----	-----	-----	-----	-----
14x12	14.000	12.750	13	13.000	11.750	.500	.500	88.97	11.188	10.126	1.406	1.312	-----	-----	-----	-----	-----	-----
16x8	16.000	8.625	14	15.000	7.625	.500	.500	97.49	12.812	6.813	1.594	.906	-----	-----	-----	-----	-----	-----
16x10	16.000	10.750	14	15.000	9.750	.500	.500	102.00	12.812	8.500	1.594	1.125	-----	-----	-----	-----	-----	-----
16x12	16.000	12.750	14	15.000	11.750	.500	.500	105.00	12.812	10.126	1.594	1.312	-----	-----	-----	-----	-----	-----
16x14	16.000	14.000	14	15.000	13.000	.500	.500	108.00	12.812	11.188	1.594	1.406	-----	-----	-----	-----	-----	-----
18x10	18.000	10.750	15	17.000	9.750	.500	.500	120.00	14.438	8.500	1.781	1.125	-----	-----	-----	-----	-----	-----
18x12	18.000	12.750	15	17.000	11.750	.500	.500	126.00	14.438	10.126	1.781	1.312	-----	-----	-----	-----	-----	-----
18x14	18.000	14.000	15	17.000	13.000	.500	.500	127.00	14.438	11.188	1.781	1.406	-----	-----	-----	-----	-----	-----
18x16	18.000	16.000	15	17.000	15.000	.500	.500	130.00	14.438	12.812	1.781	1.594	-----	-----	-----	-----	-----	-----
20x12	20.000	12.750	20	19.000	11.750	.500	.500	189.00	16.062	10.126	1.969	1.312	-----	-----	-----	-----	-----	-----
20x14	20.000	14.000	20	19.000	13.000	.500	.500	192.00	16.062	11.188	1.969	1.406	-----	-----	-----	-----	-----	-----
20x16	20.000	16.000	20	19.000	15.000	.500	.500	195.00	16.062	12.812	1.969	1.594	-----	-----	-----	-----	-----	-----
20x18	20.000	18.000	20	19.000	17.000	.500	.500	198.00	16.062	14.438	1.969	1.781	-----	-----	-----	-----	-----	-----
24x16	24.000	16.000	20	23.000	15.000	.500	.500	226.00	19.312	12.812	2.344	1.594	-----	-----	-----	-----	-----	-----
24x18	24.000	18.000	20	23.000	17.000	.500	.500	230.00	19.312	14.438	2.344	1.781	-----	-----	-----	-----	-----	-----
24x20	24.000	20.000	20	23.000	19.000	.500	.500	234.00	19.312	16.062	2.344	1.969	-----	-----	-----	-----	-----	-----



STUB ENDS - SHORT TYPE A OR B

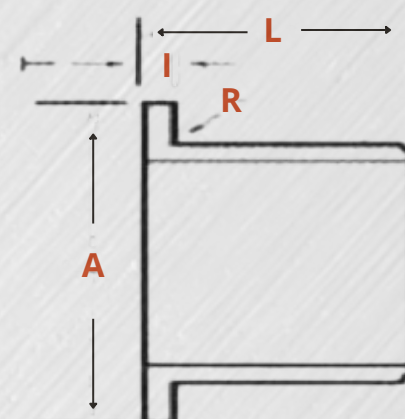

TYPE B

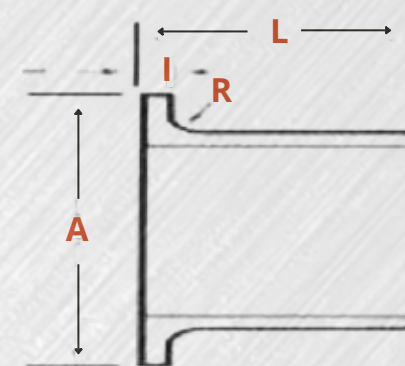

TYPE A

DIMENSIONS

Unit : inch / lb

Nominal Pipe Size	Outside diameter (O.D)	Diameter (C)	Length (J)		Radius (A)		Schedule 40S			
			Short	Long	A	B	Inside diameter (I.D.)	Wall Thickness (T)	Lap Thickness (T)	Approx. weight **
1/2	.840	1.375	2	3	1/8	1/32	.622	.109	.109	.19
3/4	1.050	1.688	2	3	1/8	1/32	.824	.113	.113	.26
1	1.315	2.000	2	4	1/8	1/32	1.049	.133	.133	.38
1-1/4	1.660	2.500	2	4	3/16	1/32	1.380	.140	.140	.55
1-1/2	1.900	2.875	2	4	1/4	1/32	1.610	.145	.145	.69
2	2.375	3.625	2-1/2	6	5/16	1/32	2.067	.154	.154	1.35
2-1/2	2.875	4.125	2-1/2	6	5/16	1/32	2.469	.203	.203	1.77
3	3.500	5.000	2-1/2	6	3/8	1/32	3.068	.216	.216	2.50
3-1/2	4.000	5.500	3	6	3/8	1/32	3.548	.226	.226	3.58
4	4.500	6.188	3	6	7/16	1/32	4.026	.237	.237	4.13
5	5.563	7.313	3	8	7/16	1/16	5.047	.258	.258	6.15
6	6.625	8.500	3-1/2	8	1/2	1/16	6.065	.280	.280	7.88
8	8.625	10.625	4	8	1/2	1/16	7.981	.322	.322	13.38
10	10.750	12.750	5	10	1/2	1/16	10.020	.365	.365	22.20
12	12.750	15.000	6	10	1/2	1/16	12.000	.375	.375	31.50
14	14.000	16.250	6	12	1/2	1/16	13.250	.375	.375	37.80
16	16.000	18.500	6	12	1/2	1/16	15.250	.375	.375	45.00
18	18.000	21.000	6	12	1/2	1/16	17.250	.375	.375	60.00
20	20.000	23.000	6	12	1/2	1/16	19.250	.375	.375	66.00
24	24.000	27.250	6	12	1/2	1/16	23.250	.375	.375	85.00



STUB ENDS - LONG TYPE A

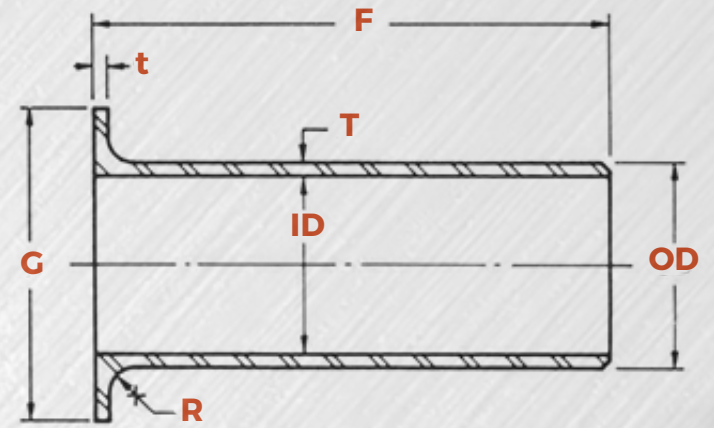

TYPE A

Schedules 80S 160 and XX Strong Wall Stub Ends are supplied in Long Lengths. Short Lengths are available on special order.

DIMENSIONS

Unit : inch / lb

Nominal Pipe Size	Outside diameter (O.D)	Diameter (G)	Length (J)	Radius (A)	Schedule 40S				Schedule 80S			
					Inside diameter (I.D.)	Wall thickness (T)	Lap Thickness (t)	Approx. weight **	Inside diameter (I.D.)	Wall Thickness (T)	Lap Thickness (t)	Approx. weight **
1/2	.840	1.375	3	1/8	.622	.109	.109	.26	.546	.147	.147	.34
3/4	1.050	1.688	3	1/8	.824	.113	.113	.36	.742	.154	.154	.47
1	1.315	2.000	4	1/8	1.049	.133	.133	.68	.957	.179	.179	.88
1-1/4	1.660	2.500	4	3/16	1.380	.140	.140	.97	1.278	.191	.191	1.26
1-1/2	1.900	2.875	4	1/4	1.610	.145	.145	1.20	1.500	.200	.200	1.49
2	2.375	3.625	6	5/16	2.067	.154	.154	2.25	1.939	.218	.218	3.05
2-1/2	2.875	4.125	6	5/16	2.469	.203	.203	3.40	2.323	.276	.276	4.40
3	3.500	5.000	6	3/8	3.068	.216	.216	4.65	2.900	.300	.300	6.50
3-1/2	4.000	5.500	6	3/8	3.548	.226	.226	5.89	3.364	.318	.318	7.75
4	4.500	6.188	6	7/16	4.026	.237	.237	6.83	3.826	.337	.337	9.65
5	5.563	7.313	8	7/16	5.047	.258	.258	11.88	4.813	.375	.375	16.33
6	6.625	8.500	8	1/2	6.065	.280	.280	15.18	5.761	.432	.432	22.63
8	8.625	10.625	8	1/2	7.981	.322	.322	23.81	7.625	.500	.500	34.12
10	10.750	12.750	10	1/2	10.020	.365	.365	39.50	9.750	.500	.500	54.00
12	12.750	15.000	10	1/2	12.000	.375	.375	48.50	11.750	.500	.500	64.50
14	14.000	16.250	12	1/2	13.250	.375	.375	63.00	13.000	.500	.500	84.00
16	16.000	18.500	12	1/2	15.250	.375	.375	73.50	15.000	.500	.500	98.00
18	18.000	21.000	12	1/2	17.250	.375	.375	99.00	17.000	.500	.500	136.00
20	20.000	23.000	12	1/2	19.250	.375	.375	108.00	19.000	.500	.500	157.00
24	24.000	27.250	12	1/2	23.250	.375	.375	139.00	23.000	.500	.500	178.00



STUB ENDS - LONG TYPE A

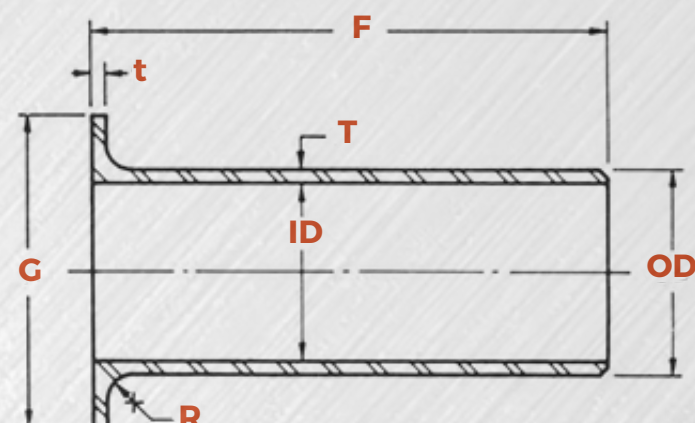

TYPE A

Schedules 80S 160 and XX Strong Wall Stub Ends are supplied in Long Lengths. Short Lengths are available on special order.

DIMENSIONS

Unit : inch / lb

Nominal Pipe Size	Outside diameter (O.D)	Diameter (G)	Lenght (F)		Radius (A)	Schedule 160				XX Strong Wall			
			Short	Long		Inside diameter (I.D.)	Wall Thickness (T)	Lap Thickness (t)	Approx. weight **	Inside diameter (I.D.)	Wall Thickness (T)	Lap Thickness (t)	Approx. weight **
1/2	.840	1.375	2	3	1/8	.464	.188	.187	.43	.252	.294	.294	.68
3/4	1.050	1.688	2	3	1/8	.612	.219	.218	.66	.434	.308	.308	.94
1	1.315	2.000	2	4	1/8	.815	.250	.250	1.22	.599	.358	.358	1.76
1-1/4	1.660	2.500	2	4	3/16	1.160	.250	.250	1.64	.896	.382	.382	2.52
1-1/2	1.900	2.875	2	4	1/4	1.338	.281	.281	2.08	1.100	.400	.400	2.98
2	2.375	3.625	2-1/2	6	5/16	1.689	.343	.343	4.79	1.503	.436	.436	6.10
2-1/2	2.875	4.125	2-1/2	6	5/16	2.125	.375	.375	5.94	1.771	.552	.552	8.80
3	3.500	5.000	2-1/2	6	3/8	2.624	.438	.438	7.10	2.300	.600	.600	9.80
3-1/2	4.000	5.500	3	6	3/8	-----	-----	-----	-----	2.728	.636	.636	15.50
4	4.500	6.188	3	6	7/16	3.438	.531	.531	15.15	3.152	.674	.674	19.30
5	5.563	7.313	3	8	7/16	4.313	.625	.625	27.10	4.063	.750	.750	32.66
6	6.625	8.500	3-1/2	8	1/2	5.187	.719	.718	37.56	4.897	.864	.864	45.26
8	8.625	10.625	4	8	1/2	6.813	.906	.906	61.75	6.875	.875	.875	59.71
10	10.750	12.750	5	10	1/2	8.500	1.125	1.125	121.50	-----	-----	-----	-----
12	12.750	15.000	6	10	1/2	10.126	1.312	1.312	169.00	-----	-----	-----	-----



STUB ENDS - SHORT TYPE C

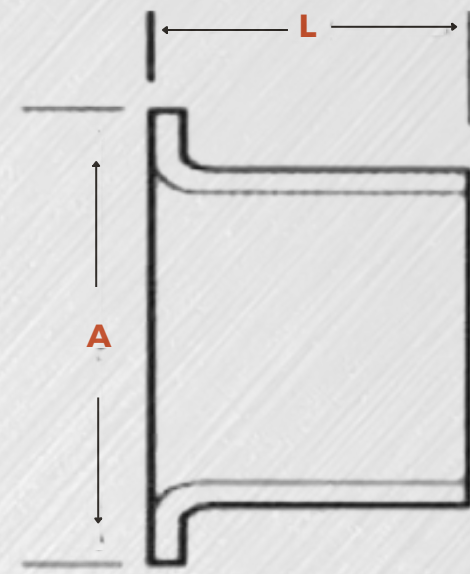

TYPE C

DIMENSIONS

Unit : inch / lb

Nominal Pipe Size	Outside diameter (O.D)	Diameter (G)	Lenght (J)	Radius (R)	Schedule 5S			Schedule 10S		
					Inside diameter (I.D.)	Wall Thickness (T)	Approx. weight **	Inside diameter (I.D.)	Wall Thickness (T)	Approx. weight **
1/2	.840	1.375	2	1/32	.710	.065	.13	.674	.083	.14
3/4	1.050	1.688	2	1/32	.920	.065	.14	.884	.083	.18
1	1.315	2.000	2	1/32	1.185	.065	.19	1.097	.109	.31
1-1/4	1.660	2.500	2	1/32	1.530	.065	.21	1.442	.109	.42
1-1/2	1.900	2.875	2	1/32	1.770	.065	.29	1.682	.109	.44
2	2.375	3.625	2-1/2	1/32	2.245	.065	.44	2.157	.109	.81
2-1/2	2.875	4.125	2-1/2	1/32	2.709	.083	.75	2.635	.120	1.00
3	3.500	5.000	2-1/2	1/32	3.334	.083	.94	3.260	.120	1.25
4	4.500	6.188	3	1/32	4.334	.083	1.38	4.260	.120	1.88
5	5.563	7.313	3	1/16	5.345	.109	2.06	5.295	.134	2.63
6	6.625	8.500	3-1/2	1/16	6.407	.109	2.75	6.357	.134	3.56
8	8.625	10.625	4	1/16	8.407	.109	3.88	8.329	.148	6.19
10	10.750	12.750	5	1/16	10.482	.134	7.48	10.420	.165	9.46
12	12.750	15.000	6	1/16	12.438	.156	15.00	12.390	.180	16.07
14	14.000	16.250	6	1/16	13.688	.156	19.20	13.624	.188	23.10
16	16.000	18.500	6	1/16	15.670	.165	23.90	15.624	.188	27.20
18	18.000	21.000	6	1/16	17.670	.165	28.50	17.624	.188	32.40
20	20.000	23.000	6	1/16	19.624	.188	36.30	19.564	.218	47.70
24	24.000	27.250	6	1/16	23.564	.218	56.00	23.500	.250	58.27



90° ELBOWS

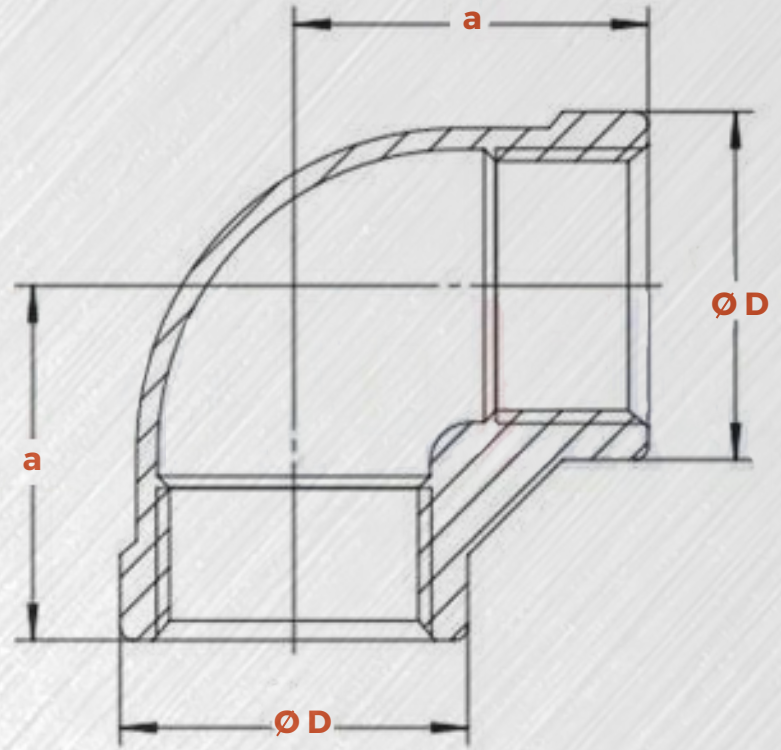

DESIGN FEATURES:
 → THREAD: NPT
 → CF8 (304) & CF8M (316)

DIMENSIONS

Unit : inch

SIZE	d1	d2	d3	C	E	G	H	I
1/8"	1/8"	0.63	0.53	0.24	0.67	0.14	0.24	0.08
1/4"	1/4"	0.75	0.61	0.37	0.77	0.16	0.24	0.08
3/8"	3/8"	0.89	0.77	0.38	0.94	0.16	0.31	0.10
1/2"	1/2"	1.10	1.02	0.39	1.14	0.12	0.30	0.08
3/4"	3/4"	1.34	1.24	0.41	1.26	0.12	0.35	0.08
1"	1"	1.69	1.61	0.55	1.46	0.16	0.39	0.10
1 1/4"	1 1/4"	2.01	1.89	0.63	1.71	0.20	0.43	0.10
1 1/2"	1 1/2"	2.32	2.22	0.61	1.89	0.20	0.47	0.10
2"	2"	2.83	2.68	0.71	2.19	0.22	0.51	0.10
2 1/2"	2 1/2"	3.54	3.39	0.87	2.64	0.35	0.55	0.12
3"	3"	4.17	4.02	0.94	3.03	0.39	0.59	0.14
4"	4"	5.20	5.00	1.02	3.78	0.33	0.65	0.14



STREET 90° ELBOWS

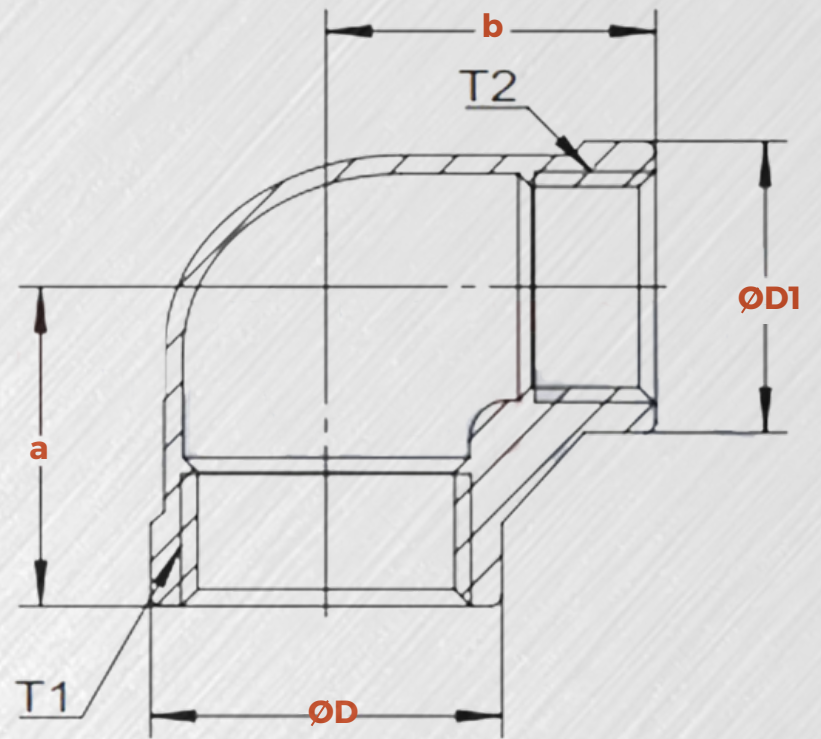

DESIGN FEATURES:
 → THREAD: NPT
 → CF8 (304) & CF8M (316)

DIMENSIONS

Unit : inch

SIZE	d1	d2	d3	C	E	H	D1	D2	D3	C1	E1	I
1/8"	1/8"	0.59	0.47	0.28	0.71	0.20	1/8"	0.20	0.35	0.31	1.02	0.08
1/4"	1/4"	0.71	0.59	0.41	0.87	0.20	1/4"	0.24	0.47	0.43	1.22	0.08
3/8"	3/8"	0.89	0.79	0.41	0.87	0.24	3/8"	0.35	0.55	0.43	1.54	0.08
1/2"	1/2"	1.10	1.02	0.39	1.06	0.31	1/2"	0.55	0.75	0.51	1.61	0.08
3/4"	3/4"	1.42	1.30	0.47	1.30	0.35	3/4"	0.79	0.98	0.51	1.85	0.08
1"	1"	1.77	1.65	0.55	1.46	0.35	1"	0.98	1.22	0.73	2.09	0.08
1 1/4"	1 1/4"	2.05	1.97	0.67	1.73	0.43	1 1/4"	1.30	1.56	0.75	2.48	0.10
1 1/2"	1 1/2"	2.36	2.24	0.67	1.85	0.43	1 1/2"	1.57	1.83	0.75	2.72	0.10
2"	2"	2.87	2.72	0.71	2.32	0.51	2"	1.97	2.24	0.85	3.15	0.10
2 1/2"	2 1/2"	3.54	3.39	0.91	2,60	0.59	2 1/2"	2.24	2.60	0.94	4.13	0.16
3"	3"	4.17	3.98	0.94	3.09	0.65	3"	2.91	3.19	1.14	4.45	0.16
4"	4"	5.14	5.04	1.02	3.86	0.77	4"	3.82	4.17	1.34	5.12	0.16



45° ELBOWS

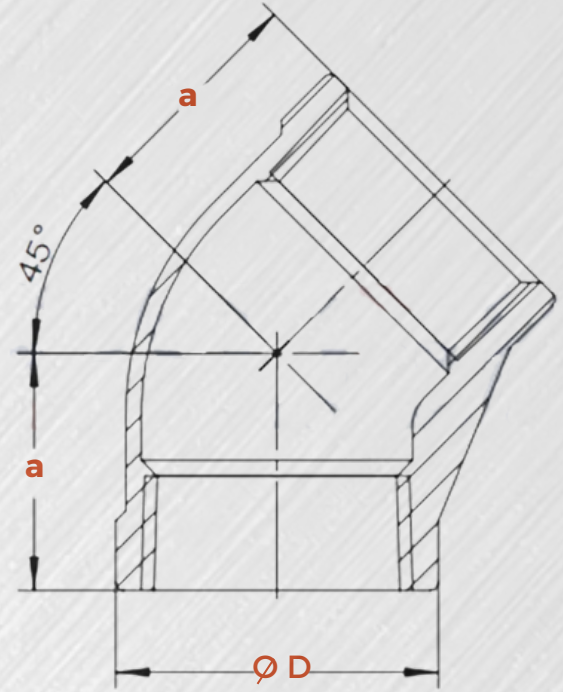

DESIGN FEATURES:
 → THREAD: NPT
 → CF8 (304) & CF8M (316)

DIMENSIONS

Unit : inch

SIZE	d1	d2	d3	C	E	H	I
1/8"	1/8"	0.63	0.53	0.28	0.63	0.24	0.08
1/4"	1/4"	0.75	0.61	0.37	0.67	0.26	0.08
3/8"	3/8"	0.89	0.77	0.38	0.75	0.24	0.08
1/2"	1/2"	1.18	1.10	0.39	0.83	0.31	0.10
3/4"	3/4"	1.42	1.34	0.43	0.94	0.39	0.10
1"	1"	1.77	1.57	0.55	1.10	0.39	0.10
1 1/4"	1 1/4"	2.22	1.91	0.61	1.30	0.43	0.10
1 1/2"	1 1/2"	2.30	2.20	0.61	1.42	0.49	0.10
2"	2"	2.83	2.68	0.65	1.65	0.51	0.10
2 1/2"	2 1/2"	3.54	3.43	0.87	1.93	0.55	0.16
3"	3"	4.17	4.00	0.98	2.13	0.59	0.16
4"	4"	6.24	4.25	0.98	2.56	0.59	0.16



ROUND CAPS

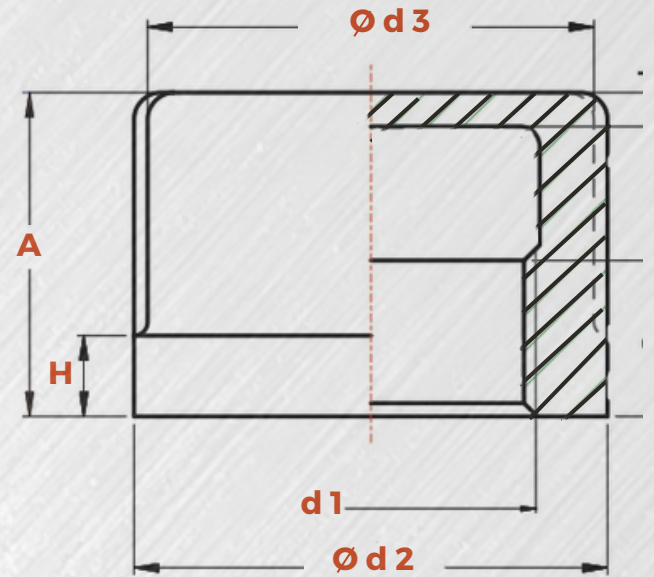

DESIGN FEATURES:
 → THREAD: NPT
 → CF8 (304) & CF8M (316)

DIMENSIONS

Unit : inch

SIZE	d1	d2	d3	A	(B)	C	H	I
1/8"	1/8"	0.63	0.53	0.59	0.47	0.24	0.26	0.12
1/4"	1/4"	0.79	0.71	0.87	0.75	0.37	0.26	0.12
3/8"	3/8"	1.00	0.93	0.96	0.87	0.38	0.30	0.10
1/2"	1/2"	1.18	1.10	1.10	0.98	0.39	0.30	0.12
3/4"	3/4"	1.42	1.30	1.10	0.98	0.39	0.33	0.12
1"	1"	1.75	1.63	1.26	1.14	0.55	0.35	0.12
1 1/4"	1 1/4"	2.09	1.97	1.28	1.12	0.65	0.43	0.16
1 1/2"	1 1/2"	2.36	2.24	1.42	1.22	0.65	0.43	0.20
2"	2"	2.91	2.76	1.54	1.34	0.71	0.47	0.20
2 1/2"	2 1/2"	3.58	3.39	1.69	1.54	0.87	0.55	0.24
3"	3"	4.33	4.09	1.87	1.63	0.91	0.55	0.24
4"	4"	5.47	5.24	2.05	1.77	1.02	0.59	0.24



HEX CAPS

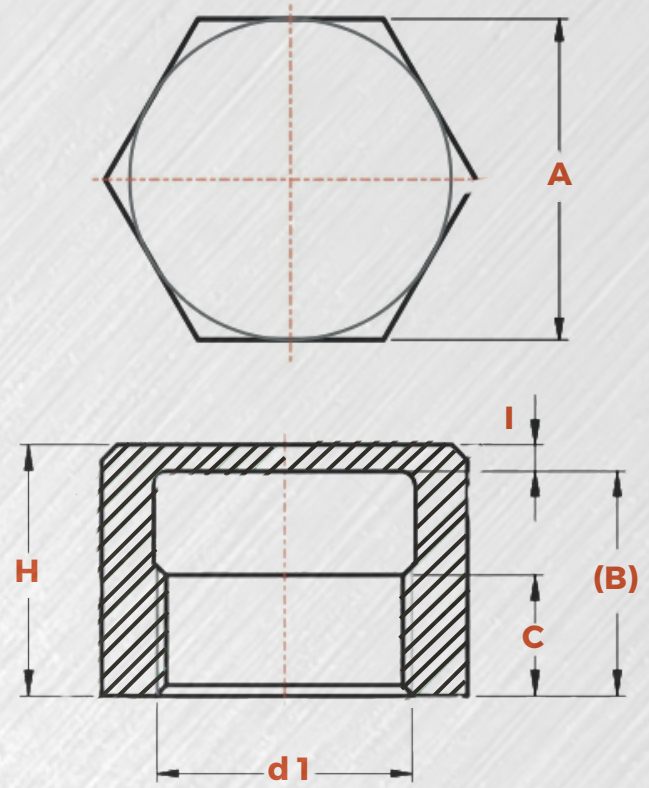

DESIGN FEATURES:
 → THREAD: NPT
 → CF8 (304) & CF8M (316)

DIMENSIONS

Unit : inch

SIZE	d1	A	(B)	C	H	I
1/8"	1/8"	0.63	0.51	0.24	0.63	0.12
1/4"	1/4"	0.71	0.67	0.37	0.79	0.12
3/8"	3/8"	0.79	0.71	0.38	0.83	0.12
1/2"	1/2"	1.02	0.77	0.39	0.89	0.12
3/4"	3/4"	1.26	0.79	0.39	0.91	0.12
1"	1"	1.54	0.91	0.53	1.02	0.12
1 1/4"	1 1/4"	1.93	0.96	0.63	1.12	0.16
1 1/2"	1 1/2"	2.17	1.10	0.67	1.26	0.16
2"	2"	2.60	1.26	0.91	1.38	0.12
2 1/2"	2 1/2"	3.35	1.42	0.91	1.65	0.24
3"	3"	3.94	1.61	0.98	1.79	0.24
4"	4"	4.92	1.93	1.02	2.17	0.24



SQUARE HEAD PLUGS

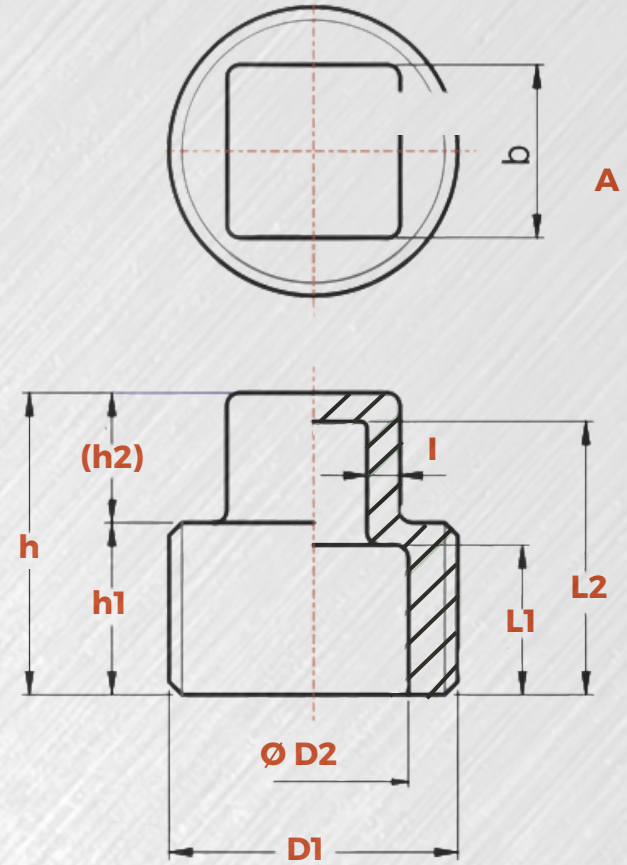

DESIGN FEATURES:
 → THREAD: NPT
 → CF8 (304) & CF8M (316)

DIMENSIONS

Unit : inch

SIZE	b	D1	D2	L1	L2	h	h1	(h2)	l
1/8"	0.28	1/8"	-	-	-	0.71	0.39	0.31	-
1/4"	0.35	1/4"	-	-	-	0.75	0.39	0.35	-
3/8"	0.39	3/8"	-	-	-	0.79	0.43	0.35	-
1/2"	0.51	1/2"	0.57	0.47	0.83	0.91	0.51	0.39	0.10
3/4"	0.71	3/4"	0.71	0.57	1.02	1.18	0.71	0.47	0.10
1"	0.75	1"	0.98	0.71	1.22	1.30	0.83	0.47	0.10
1 1/4"	0.91	1 1/4"	1.34	0.75	1.42	1.54	0.91	0.63	0.10
1 1/2"	1.02	1 1/2"	1.54	0.83	1.42	1.57	0.91	0.67	0.10
2"	1.14	2"	1.97	0.91	1.65	1.77	1.02	0.75	0.10
2 1/2"	1.57	2 1/2"	2.36	0.94	1.61	1.89	1.10	0.79	0.12
3"	1.73	3"	2.95	1.06	1.97	2.13	1.26	0.87	0.12
4"	2.32	4"	3.98	1.22	2.17	2.32	1.46	0.87	0.12



HEX HEAD PLUGS

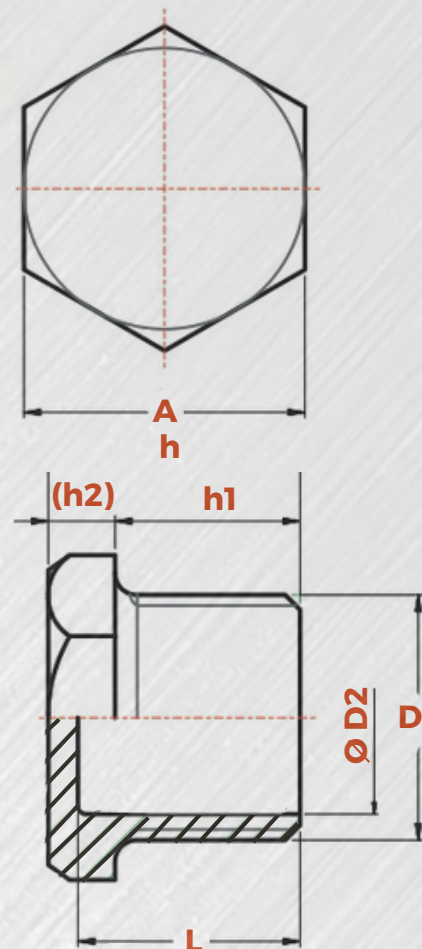

DESIGN FEATURES:
 → THREAD: NPT
 → CF8 (304) & CF8M (316)

DIMENSIONS

Unit : inch

SIZE	D1	D2	L	A	h	h1	(h2)
1/8"	1/8"	-	-	0.55	0.71	0.43	0.24
1/4"	1/4"	-	-	0.67	0.91	0.67	0.24
3/8"	3/8"	0.35	0.81	0.83	0.93	0.67	0.26
1/2"	1/2"	0.57	0.98	1.02	1.10	0.79	0.31
3/4"	3/4"	0.71	0.98	1.26	1.10	0.79	0.31
1"	1"	1.02	1.18	1.50	1.34	0.98	0.35
1 1/4"	1 1/4"	1.34	1.22	1.81	1.38	0.98	0.39
1 1/2"	1 1/2"	1.52	1.30	2.05	1.42	0.98	0.43
2"	2"	1.97	1.34	2.56	1.48	1.02	0.45
2 1/2"	2 1/2"	2.36	1.38	3.15	1.57	1.10	0.47
3"	3"	2.95	1.54	3.74	1.77	1.26	0.51
4"	4"	3.98	1.77	4.72	2.02	1.46	0.55



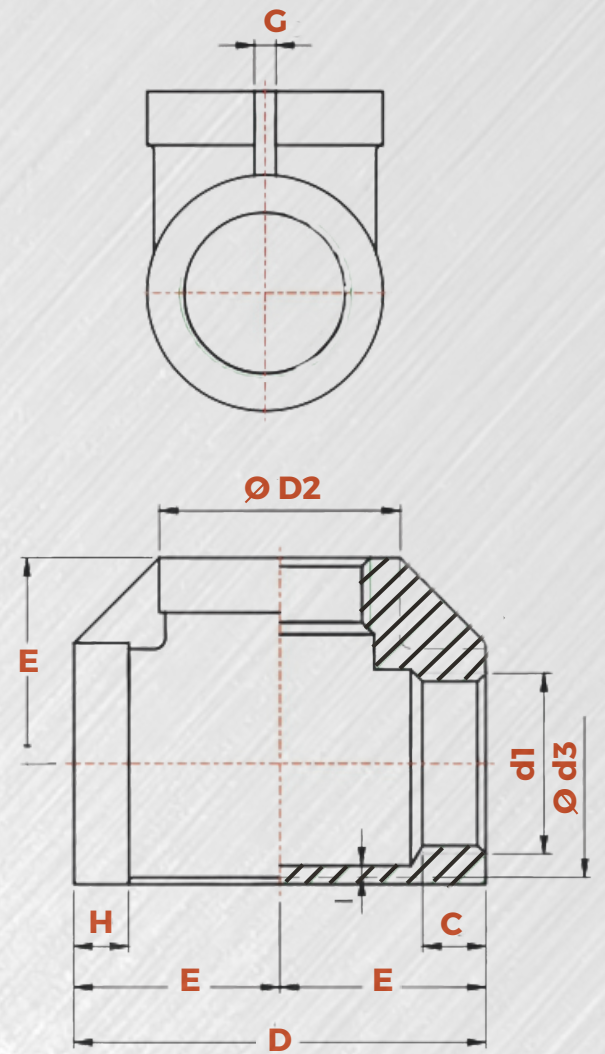

DESIGN FEATURES:
 → THREAD: NPT
 → CF8 (304) & CF8M (316)

DIMENSIONS

Unit : inch

SIZE	d1	d2	d3	C	D	E	G	H	I
1/8"	1/8"	0.63	0.53	0.24	1.42	0.71	0.12	0.24	0.10
1/4"	1/4"	0.75	0.61	0.37	1.04	0.77	0.12	0.24	0.08
3/8"	3/8"	0.89	0.77	0.38	1.85	0.93	0.12	0.26	0.10
1/2"	1/2"	1.10	1.02	0.39	2.28	1.14	0.12	0.30	0.08
3/4"	3/4"	1.34	1.24	0.39	2.56	1.28	0.12	0.33	0.08
1"	1"	1.69	1.57	0.51	2.91	1.46	0.16	0.37	0.08
1 1/4"	1 1/4"	2.01	1.89	0.65	3.50	1.75	0.20	0.41	0.08
1 1/2"	1 1/2"	2.32	2.22	0.63	3.82	1.91	0.20	0.45	0.10
2"	2"	2.83	2.68	0.71	4.45	2.22	0.24	0.47	0.10
2 1/2"	2 1/2"	3.54	3.39	0.91	5.35	2.68	0.35	0.57	0.16
3"	3"	4.17	4.00	0.96	6.18	3.09	0.39	0.59	0.16
4"	4"	5.20	5.00	1.02	7.68	3.84	0.35	0.61	0.16



CROSSES

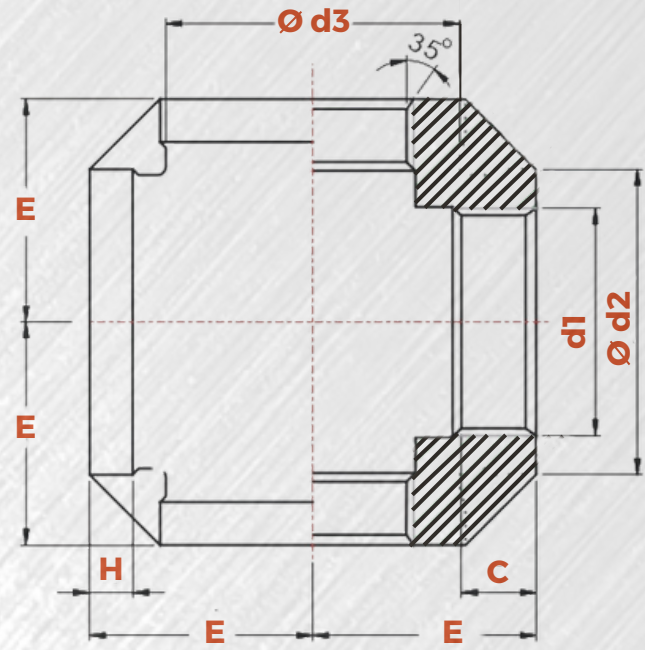

DESIGN FEATURES:
 → THREAD: NPT
 → CF8 (304) & CF8M (316)

DIMENSIONS

Unit : inch

SIZE	d1	d2	d3	C	E	H
1/8"	1/8"	0.63	0.55	0.24	0.69	0.24
1/4"	1/4"	0.79	0.71	0.37	0.75	0.28
3/8"	3/8"	0.98	0.91	0.38	0.91	0.28
1/2"	1/2"	1.18	1.10	0.39	1.14	0.28
3/4"	3/4"	1.42	1.34	0.43	1.28	0.35
1"	1"	1.77	1.65	0.55	1.48	0.39
1 1/4"	1 1/4"	2.09	1.97	0.71	1.73	0.43
1 1/2"	1 1/2"	2.36	2.20	0.71	1.89	0.47
2"	2"	2.87	2.76	0.71	2.32	0.51
2 1/2"	2 1/2"	3.54	3.39	0.87	2.68	0.55
3"	3"	4.17	4.02	0.98	3.07	0.59
4"	4"	5.20	5.04	1.02	3.82	0.63



UNIONS - THREADED

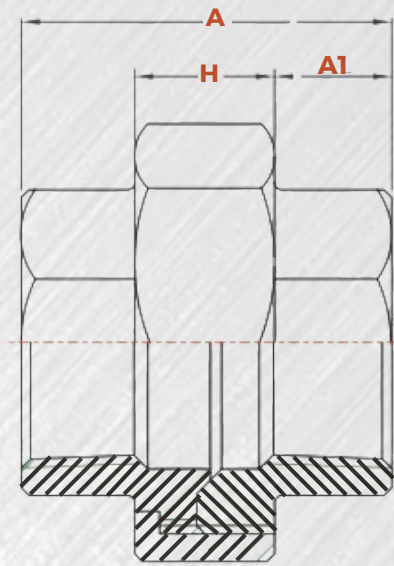
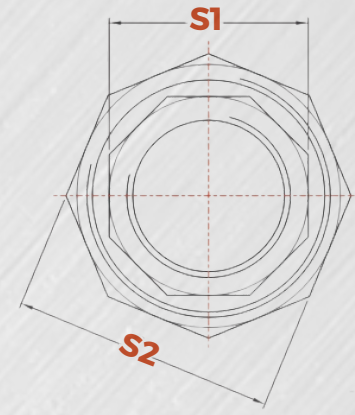

DESIGN FEATURES:
 → THREAD: NPT
 → CF8 (304) & CF8M (316)

DIMENSIONS

Unit : inch

SIZE	A	A1	H	S1	S2
1/8"	1.46	0.47	0.59	0.71	1.14
1/4"	1.46	0.47	0.59	0.71	1.14
3/8"	1.54	0.47	0.63	0.91	1.42
1/2"	1.61	0.51	0.59	1.06	1.61
3/4"	1.65	0.63	0.63	1.26	1.93
1"	2.01	0.67	0.71	1.61	2.28
1 1/4"	2.05	0.63	0.83	1.97	2.68
1 1/2"	2.20	0.71	0.87	2.20	3.03
2"	2.36	0.71	0.98	2.72	3.62
2 1/2"	2.95	1.02	0.98	3.35	4.29
3"	3.50	1.18	1.14	3.90	4.92
4"	3.90	1.26	1.34	4.92	6.14



UNIONS - SOCKET

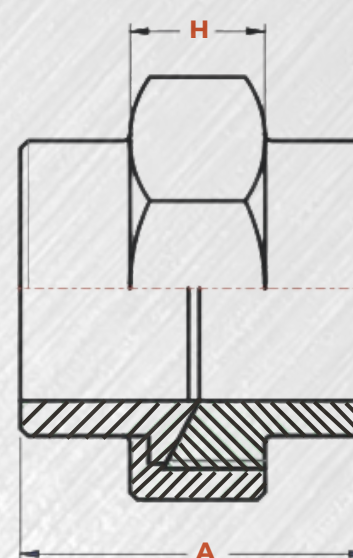
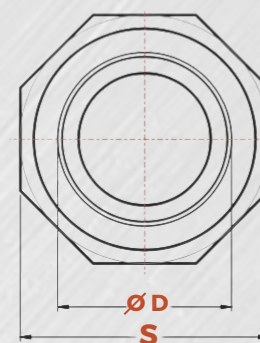

DESIGN FEATURES:
 → THREAD: NPT
 → CF8 (304) & CF8M (316)

DIMENSIONS

Unit : inch

SIZE	A	D	S	H
1/4"	1.26	0.54	1.14	0.55
3/8"	1.50	0.68	1.42	0.55
1/2"	1.57	0.85	1.61	0.55
3/4"	1.85	1.07	1.93	0.55
1"	1.95	1.34	2.58	0.71
1 1/4"	2.13	1.69	2.67	0.75
1 1/2"	2.24	1.91	3.02	0.83
2"	2.36	2.39	3.60	0.94
2 1/2"	2.76	3.00	4.29	0.94
3"	3.19	3.51	4.92	1.10



HEX BUSHINGS

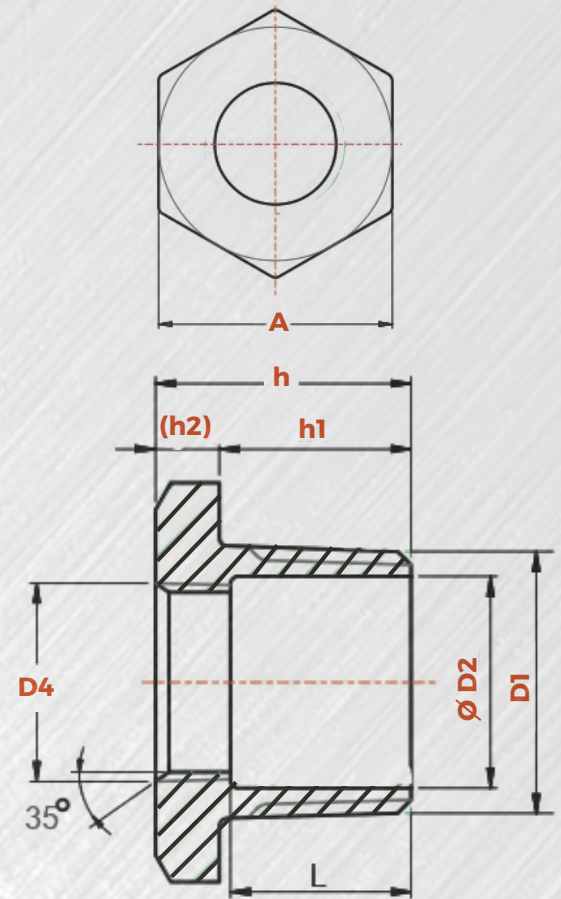

DESIGN FEATURES:

→ THREAD: NPT

→ CF8 (304) & CF8M (316)

DIMENSIONS

Unit : inch

SIZE	A	L	D1	D2	D4	h	h1	(h2)
1/4" X 1/8"	0.67	0.59	1/4"	0.33	1/8"	0.89	0.67	0.22
3/8" x 1/8"	0.87	0.59	3/8"	0.43	1/8"	0.91	0.67	0.24
3/8" x 1/4"	0.87	-	3/8"	0.43	1/4"	0.91	0.67	0.24
1/2" x 1/8"	1.02	0.67	1/2"	0.57	1/8"	1.00	0.79	0.22
1/2" x 1/4"	1.02	0.67	1/2"	0.57	1/4"	1.00	0.79	0.22
1/2" x 3/8"	1.02	-	1/2"	0.57	3/8"	1.00	0.79	0.22
3/4" x 1/8"	1.26	0.69	3/4"	0.71	1/8"	1.04	0.79	0.26
3/4" x 1/4"	1.26	0.69	3/4"	0.71	1/4"	1.04	0.79	0.26
3/4" x 3/8"	1.26	0.69	3/4"	0.71	3/8"	1.04	0.79	0.26
3/4" x 1/2"	1.26	-	3/4"	0.71	1/2"	1.04	0.79	0.26
1" x 1/8"	1.50	0.96	1"	1.02	1/8"	1.32	1.00	0.31
1" x 1/4"	1.50	0.96	1"	1.02	1/4"	1.32	1.00	0.31
1" x 3/8"	1.50	0.96	1"	1.02	3/8"	1.32	1.00	0.31
1" x 1/2"	1.50	0.87	1"	1.02	1/2"	1.32	1.00	0.31
1" x 3/4"	1.50	0.81	1"	1.02	3/4"	1.32	1.00	0.31
1 1/4" x 1/8"	1.81	1.02	1 1/4"	13.8	1/8"	1.34	1.02	0.31
1 1/4" x 1/4"	1.81	0.96	1 1/4"	13.8	1/4"	1.34	1.02	0.31
1 1/4" x 3/8"	1.81	0.96	1 1/4"	13.8	3/8"	1.34	1.02	0.31
1 1/4" x 1/2"	1.81	0.91	1 1/4"	13.8	1/2"	1.34	1.02	0.31
1 1/4" x 3/4"	1.81	0.83	1 1/4"	13.8	3/4"	1.34	1.02	0.31
1 1/4" x 1"	1.81	0.77	1 1/4"	13.8	1"	1.34	1.02	0.31



HEX BUSHINGS

DIMENSIONS

Unit : inch

SIZE	A	L	D1	D2	D4	h	h1	(h2)
1 1/2" X 1/8"	2.05	1.06	1 1/2"	1.57	1/8"	1.42	1.02	0.39
1 1/2" x 1/4"	2.05	1.06	1 1/2"	1.57	1/4"	1.42	1.02	0.39
1 1/2" x 3/8"	2.05	1.02	1 1/2"	1.57	3/8"	1.42	1.02	0.39
1 1/2" x 1/2"	2.05	0.94	1 1/2"	1.57	1/2"	1.42	1.02	0.39
1 1/2" x 3/4"	2.05	0.91	1 1/2"	1.57	3/4"	1.42	1.02	0.39
1 1/2" x 1"	2.05	0.83	1 1/2"	1.57	1"	1.42	1.02	0.39
1 1/2"x1 1/4"	2.05	0.73	1 1/2"	1.57	1 1/4"	1.42	1.02	0.39
2" x 1/8"	2.48	1.10	2"	2.01	1/8"	1.42	1.00	0.41
2" x 1/4"	2.48	1.06	2"	2.01	1/4"	1.42	1.00	0.41
2" x 3/8"	2.48	1.06	2"	2.01	3/8"	1.42	1.00	0.41
2" x 1/2"	2.48	0.98	2"	2.01	1/2"	1.42	1.00	0.41
2" x 3/4"	2.48	0.91	2"	2.01	3/4"	1.42	1.00	0.41
2" x 1"	2.48	0.87	2"	2.01	1"	1.42	1.00	0.41
2"x 1 1/4"	2.48	0.79	2"	2.01	1 1/4"	1.42	1.00	0.41
2" x 1 1/2"	2.48	0.79	2"	2.01	1 1/2"	1.42	1.00	0.41
2 1/2" x 1/2"	3.15	1.52	2 1/2"	2.48	1/2"	1.93	1.46	0.47
2 1/2" x 3/4"	3.15	1.44	2 1/2"	2.48	3/4"	1.93	1.46	0.47
2 1/2" x 1"	3.15	1.36	2 1/2"	2.28	1"	1.93	1.46	0.47
2 1/2"x1 1/4"	3.15	1.24	2 1/2"	2.48	1 1/4"	1.93	1.46	0.47
2 1/2"x1 1/2"	3.15	1.18	2 1/2"	2.48	1 1/2"	1.93	1.46	0.47
2 1/2" x 2"	3.15	1.14	2 1/2"	2.48	2"	1.93	1.46	0.47
3" x 1/2"	3.74	1.54	3"	3.03	1/2"	1.97	1.46	0.51
3" x 3/4"	3.74	1.46	3"	3.03	3/4"	1.97	1.46	0.51
3" x 1"	3.74	1.38	3"	3.03	1"	1.97	1.46	0.51
3" x 1 1/4"	3.74	1.26	3"	3.03	1 1/4"	1.97	1.46	0.51
3" x 1 1/2"	3.74	1.22	3"	3.03	1 1/2"	1.97	1.46	0.51
3" x 2"	3.74	1.18	3"	3.03	2"	1.97	1.46	0.51
3" x 2 1/2"	3.74	1.02	3"	3.03	2 1/2"	1.97	1.46	0.51
4" x 1/2"	4.72	1.57	4"	3.98	1/2"	2.01	1.46	0.55
4" x 3/4"	4.72	1.52	4"	3.98	3/4"	2.01	1.46	0.55
4" x 1"	4.72	1.42	4"	3.98	1"	2.01	1.46	0.55
4" x 1 1/4"	4.72	1.32	4"	3.98	1 1/4"	2.01	1.46	0.55
4" x 1 1/2"	4.72	1.26	4"	3.98	1 1/2"	2.01	1.46	0.55
4" x 2"	4.72	1.22	4"	3.98	2"	2.01	1.46	0.55
4" x 2 1/2"	4.72	1.10	4"	3.98	2 1/2"	2.01	1.46	0.55
4" x 3"	4.72	1.02	4"	3.98	3"	2.01	1.46	0.55



COUPLINGS

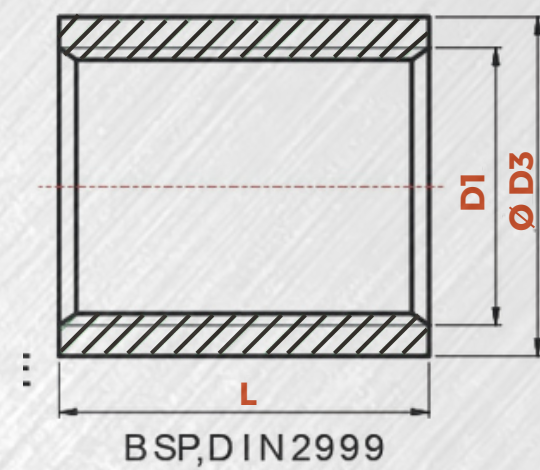
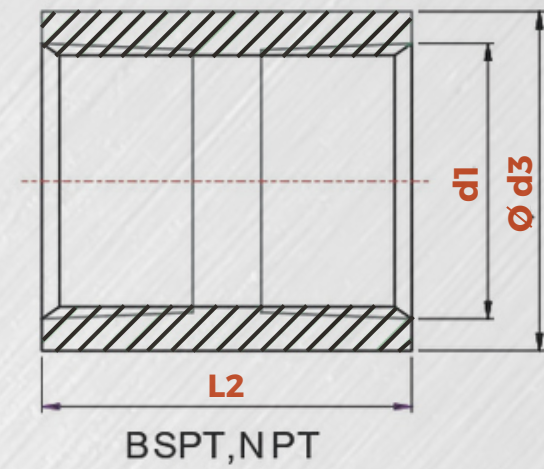

DESIGN FEATURES:

➔ THREAD: NPT

➔ CF8 (304) & CF8M (316)

➔ MADE FROM STAINLESS STEEL WELDED PIPE

DIMENSIONS

Unit : inch

SIZE	d1	BSPT, NPT		D1	BSP, DIN 2999	
		d3	L2		D3	L
1/8"	1/8"	0.55	0.79	1/8"	0.55	0.79
1/4"	1/4"	0.73	1.06	1/4"	0.73	0.98
3/8"	3/8"	0.85	1.10	3/8"	0.85	1.02
1/2"	1/2"	1.04	1.42	1/2"	1.04	1.34
3/4"	3/4"	1.26	1.54	3/4"	1.26	1.42
1"	1"	1.56	1.69	1"	1.56	1.69
1 1/4"	1 1/4"	1.91	1.89	1 1/4"	1.91	1.89
1 1/2"	1 1/2"	2.15	1.89	1 1/2"	2.15	1.89
2"	2"	2.62	2.20	2"	2.62	2.20
2 1/2"	2 1/2"	3.31	2.56	2 1/2"	3.31	2.56
3"	3"	3.94	2.80	3"	3.74	2.80
4"	4"	5.08	3.27	4"	4.80	3.27
5"	5"	6.36	3.54	-	-	-
6"	6"	7.28	3.96	-	-	-



HALF COUPLINGS

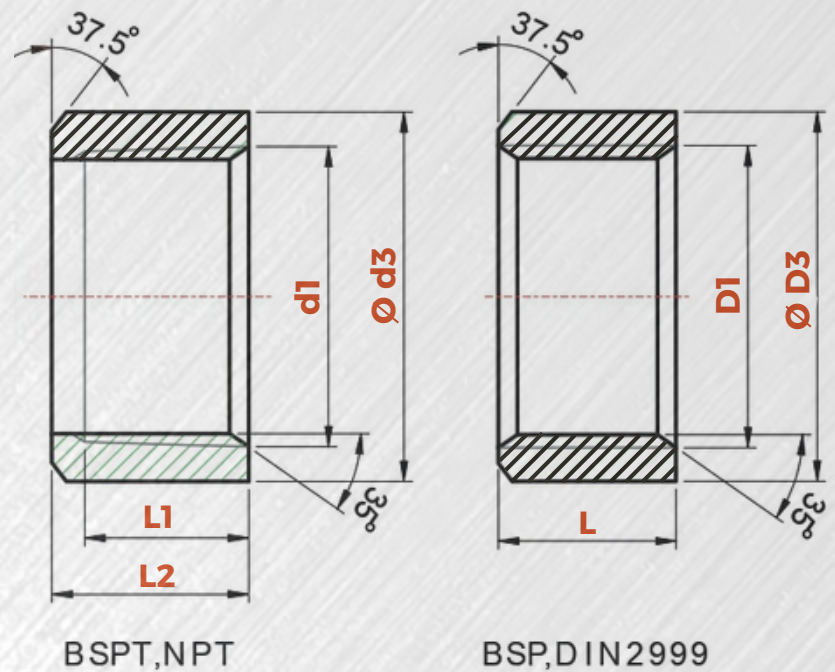

BSPT,NPT

BSP,DIN2999

DESIGN FEATURES:

- ➡ THREAD: NPT
- ➡ CF8 (304) & CF8M (316)
- ➡ MADE FROM STAINLESS STEEL WELDED PIPE

DIMENSIONS

Unit : inch

SIZE	d1	BSPT,NPT		D1	BSP, DIN2999	
		d3	L2		D3	L
1/8"	1/8"	0.56	0.43	1/8"	0.55	0.43
1/4"	1/4"	0.73	0.51	1/4"	0.73	0.43
3/8"	3/8"	0.85	0.55	3/8"	0.85	0.47
1/2"	1/2"	1.04	0.71	1/2"	1.04	0.59
3/4"	3/4"	1.26	0.79	3/4"	1.26	0.67
1"	1"	1.56	0.83	1"	1.56	0.75
1 1/4"	1 1/4"	1.91	0.94	1 1/4"	1.91	0.87
1 1/2"	1 1/2"	2.15	0.94	1 1/2"	2.15	0.87
2"	2"	2.62	1.10	2"	2.62	1.02
2 1/2"	2 1/2"	3.31	1.30	2 1/2"	3.23	1.18
3"	3"	3.94	1.42	3"	3.74	1.30
4"	4"	5.08	1.65	4"	4.80	1.57



PLUGS & BUSHINGS

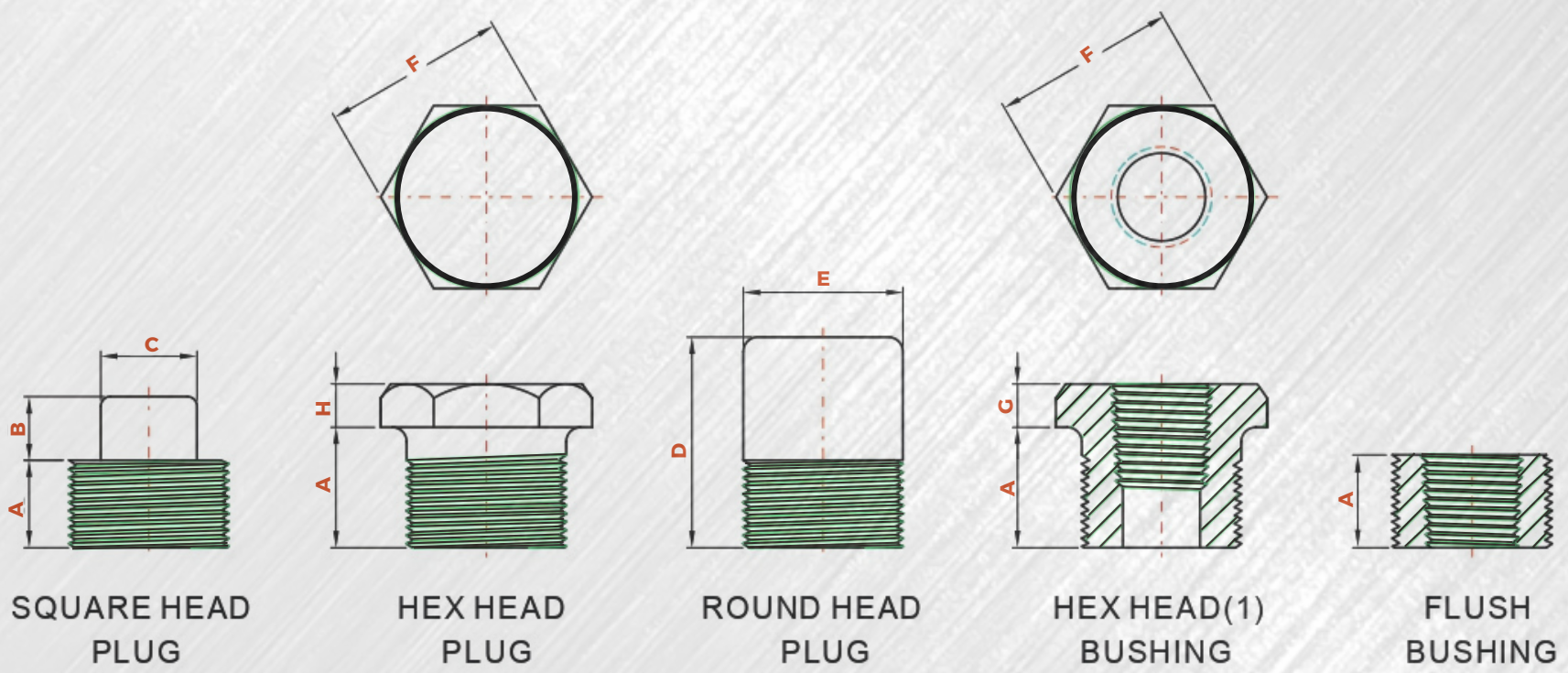

DIMENSIONS

Unit : inch

DN	Nom. Pipe Size	Length (Min.) A	Plugs Square Head		Plugs Round Head		Hex Plugs & Bushings		
			Height of Square (Min.) B	Width Flats (Min.) C	Nominal Diameter of Head E	Length (Min.) D	Width Flats (Nom.) F	Hex Height (Min.)	
								Bushing G	Plug H
6	1/8	0.394	0.236	0.276	0.394	1.378	0.433	----	0.236
8	1/4	0.433	0.236	0.394	0.551	1.614	0.630	0.118	0.236
10	3/8	0.512	0.315	0.433	0.709	1.614	0.709	0.157	0.315
15	1/2	0.551	0.394	0.551	0.827	1.732	0.866	0.197	0.315
20	3/4	0.630	0.433	0.630	1.063	1.732	1.063	0.236	0.394
25	1	0.748	0.512	0.827	1.299	2.008	1.417	0.236	0.394
32	1-1/4	0.827	0.551	0.945	1.693	2.008	1.811	0.276	0.551
40	1-1/2	0.827	0.630	1.102	1.890	2.008	1.969	0.315	0.630
50	2	0.866	0.709	1.260	2.362	2.520	2.559	0.354	0.709
65	2-1/2	1.063	0.748	1.417	2.874	2.756	2.953	0.394	0.748
80	3	1.102	0.827	1.614	3.504	2.756	3.543	0.394	0.827
100	4	1.260	0.984	2.559	4.488	2.992	4.528	0.512	0.984



STREET 90° ELBOWS

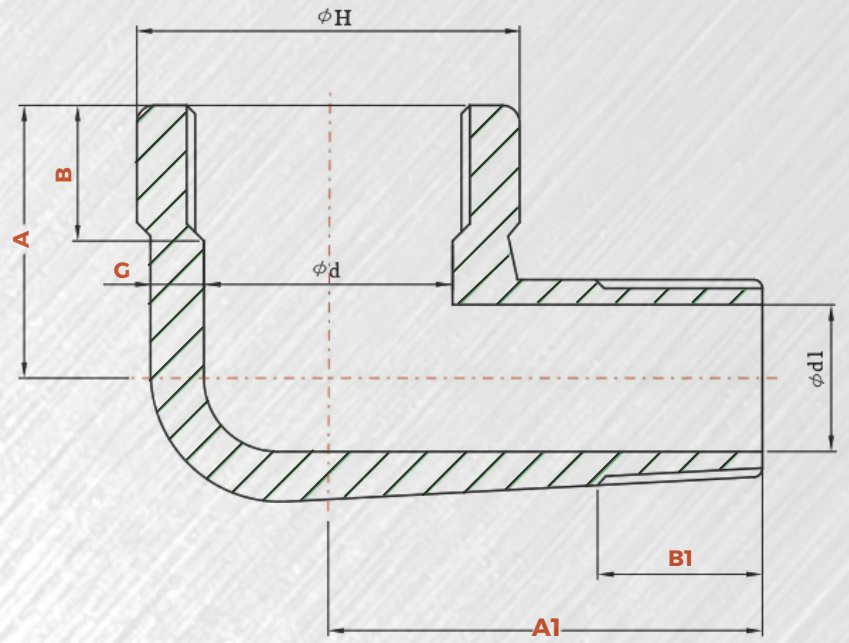

DIMENSIONS

3000 Lbs

Unit : inch

Dim Nom. Pipe Size	H	A	A1	d	d1	C (Min)	B (Min)	B1 (Min)
1/4	0.984	0.874	1.248	0.441	0.276	0.130	0.315	0.406
3/8	1.299	1.000	1.500	0.571	0.354	0.138	0.354	0.409
1/2	1.496	1.126	1.622	0.618	0.512	0.161	0.433	0.535
3/4	1.811	1.374	1.874	0.823	0.630	0.170	0.492	0.543
1	2.205	1.752	2.268	1.047	0.787	0.196	0.571	0.681
1-1/4	2.441	2.000	2.626	1.378	1.102	0.208	0.669	0.709
1-1/2	2.953	2.126	2.811	1.610	1.181	0.219	0.709	0.724
2	3.307	2.500	3.307	2.067	1.575	0.281	0.748	0.760

6000 Lbs

Unit : inch

Dim Nom. Pipe Size	H	A	A1	d	d1	C (Min)	B (Min)	B1 (Min)
1/4	1.299	1.000	1.500	0.441	0.118	0.260	0.315	0.406
3/8	1.496	1.126	1.622	0.571	0.185	0.275	0.354	0.409
1/2	1.811	1.374	1.874	0.618	0.248	0.321	0.433	0.535
3/4	2.205	1.752	2.252	0.823	0.437	0.336	0.492	0.543
1	2.441	2.000	2.626	1.047	0.598	0.391	0.571	0.681
1-1/4	2.441	2.000	2.626	1.378	1.102	0.208	0.669	0.709
1-1/2	3.307	2.500	3.307	1.610	1.098	0.436	0.709	0.724



STANDARD BULK QUALITY

DIMENSIONS

Unit : pcs

SIZE NPS	90D ELB 3000# SW	90D ELB 3000# NTP 6000# SW	45D ELB 3000# SW	45D ELB 3000#NTP 6000# SW	TEE 3000# SW	TEE 3000# NTP 6000# SW	CPLG 3000# SW1	CPLG 3000# NTP	UNION NTP SW	H.CPLG NTP SW	CAP 3000# NTP/SW	BUSH NTP	NIPPLE NTP	HEX PLUG NTP
1/4"	150	100	150	100	100	80	350	250	70	350	300	600	500	800
3/8"	100	80	100	80	80	50	250	200	70	300	250	500	400	600
1/2"	80	50	80	50	50	35	120	100	50	150	130	400	200	250
3/4"	50	30	50	30	35	20	80	70	35	120	80	200	120	200
1"	30	20	30	20	20	15	50	35	20	80	50	100	80	100
1-1/4"	20	15	20	15	15	10	30	20	14	50	30	70	35	35
1-1/2"	15	6	15	8	10	5	20	15	10	40	20	50	30	25
2"	8	5	10	6	6	4	15	10	6	20	15	25	15	17
2-1/2"	4	2	6	4	4	3	10	5	2	6	10	15	5	8
3"	2	1	3	2	2	1	6	3	1	5	4	10	3	6

SIZE OF CARTON: 1.10 in x 0.79in x 0.71in



WEIGHT LIST

DIMENSIONS

Unit : lb / pc

SIZE	1/8	1/4	3/8	1/2"	3/4"	1"	1-1/4"	1-1/2"	2"	2-1/2"	3"	4"
3000 LBS SCREWED												
90° ELBOW	0.22	0.31	0.59	0.90	1.59	2.27	2.89	4.87	5.44	9.98	17.11	29.23
45° ELBOW	0.18	0.26	0.53	0.75	1.19	2.03	2.14	4.05	4.25	7.62	11.98	19.74
TEE	0.29	0.29	0.84	1.23	1.85	3.74	4.30	7.00	8.00	13.74	20.99	37.97
COUPLING	0.11	0.14	0.13	0.29	0.42	0.86	1.50	2.18	3.02	4.56	6.78	11.98
HALF COUPLING	0.07	0.07	0.07	0.13	0.22	0.44	0.75	1.10	1.50	2.27	3.39	5.99
CAP	0.09	0.09	0.11	0.24	0.40	0.77	1.32	1.54	2.33	4.05	5.84	10.07
STREES ELBOW	0.22	0.34	0.59	0.90	1.45	2.14	2.89	4.87	5.44			
UNION	0.62	0.62	0.62	0.68	1.01	1.48	2.27	3.33	5.35	7.67	11.56	26.43
6000 LBS SCREWED												
90° ELBOW	0.37	0.66	0.99	1.59	2.53	3.55	5.88	7.05	13.00	21.76	36.19	
45° ELBOW	0.24	0.59	0.86	1.34	2.25	2.58	5.88	5.75	9.63	15.44	31.19	
TEE	0.44	0.93	1.39	2.16	3.63	4.82	7.75	9.74	17.36	28.88	49.56	
COUPLING	0.18	0.13	0.40	0.68	0.90	1.87	2.31	4.12	7.49	9.25	13.44	2.11
HALF COUPLING	0.09	0.09	0.20	0.35	0.44	0.95	1.17	2.00	3.74	4.63	6.72	11.06
CAP	0.13	0.13	0.20	0.31	0.44	0.75	1.30	1.70	3.24			
PLUG BUSHING 3000 / 6000 LBS												
SQUARE HEAD	0.02	0.02	0.07	0.11	0.10	0.35	0.59	0.84	1.39	2.11	3.37	8.44
HEX HEAD	0.02	0.07	0.11	0.45	0.31	0.55	1.04	1.37	2.42	3.81	4.74	13.00
ROUND HEAD	0.04	0.14	0.15	0.26	0.44	0.75	1.21	1.59	3.11	4.87	7.48	13.24
BUSHING		0.02	0.02	0.07	0.11	0.20	0.55	0.75	0.99	1.32	2.56	7.05
3000 LBS SCREWED WELD												
90° ELBOW	0.20	0.22	0.22	0.48	0.68	1.17	1.59	2.14	3.77	8.37	12.11	24.12
45° ELBOW	0.15	0.43	0.20	0.44	0.57	0.88	1.41	1.70	2.69	7.86	11.23	20.73
TEE	0.24	0.20	0.33	0.70	0.93	1.43	2.18	2.97	4.56	8.59	13.00	31.28
COUPLING	0.09	0.14	0.15	0.29	0.42	0.59	1.08	1.30	2.14	3.13	4.14	7.29
HALF COUPLING	0.09	0.44	0.15	0.29	0.42	0.59	1.08	1.30	2.14	3.13	4.14	7.29
CAP	0.07	0.09	0.11	0.22	0.35	0.48	2.89	1.12	1.87	2.73	4.27	7.29
UNION	0.62	0.62	0.62	0.68	1.01	1.48	2.27	3.33	5.35	7.67	11.56	26.43
6000 LBS SCREWED WELD												
90° ELBOW				0.88	1.39	2.62	3.00	5.31	5.99	10.46	18.83	31.52
45° ELBOW				0.66	1.26	1.94	2.44	4.43	4.74	8.92	13.26	24.60
TEE				1.19	1.94	3.17	4.07	7.20	7.93	15.29	23.37	37.27
COUPLING				0.53	0.73	1.43	1.65	2.64	4.67	6.30	8.84	13.99
HALF COUPLING				0.53	0.73	1.43	1.65	2.64	4.67	6.30	8.83	13.99
CAP				0.42	0.57	1.17	1.41	2.14	3.61	4.89	7.60	13.28



NIPPLES

STANDARD NIPPLE WEIGHY (LBS) CWT - MULTIPLY BY 1.3 FOR XH									
NOMINAL PIPE SIZE	CLOSE LENGHT	CLOSE	1 1/2	2	2 1/2	3	3 1/2	4	4 1/2
1/8	3/4	1.2	2.6	3.6	4.8	5.8	6.8	7.8	8.6
1/4	7/8	2.5	4.4	6.0	7.6	9.2	10.2	13.0	14.0
3/8	1	3.4	6.0	7.8	10.0	12.2	15.0	17.6	19.6
1/2	1 1/8	5.6	8.0	11.6	14.8	18.2	21.6	25.2	28.6
3/4	1 3/8	9.6	11.2	15.8	19.8	24.2	28.8	32.0	38.0
1	1 1/2	14.8	-	22.0	25.2	35.6	39.6	47.0	52.6
1 1/4	1 5/8	22.5	-	32.0	40.0	48.5	60.0	61.5	71.5
1 1/2	1 3/4	29.5	-	32.0	46.5	56.0	68.0	79.5	91.0
2	2	40.0	-	-	61.5	71.0	93.0	107.0	122.5
2 1/2	2 1/2	73.0	-	-	-	95.0	135.0	145.0	179.5
3	2 5/8	119.0	-	-	-	148.5	167.5	206.0	237.5
4	2 7/8	194.4	-	-	-	200.0	-	298.8	362.5
STANDARD NIPPLE WEIGHY (LBS) CWT - MULTIPLY BY 1.3 FOR XH									
NOMINAL PIPE SIZE	5	5 1/2	6	7	8	9	10	11	12
1/8	10.6	11.2	12.0	14.6	16.4	18.9	20.6	22.4	24.6
1/4	15.4	18.0	20.2	22.4	26.8	29.8	35.2	38.4	42.0
3/8	22.2	23.0	26.4	32.4	35.0	39.2	47.6	50.6	51.8
1/2	31.6	35.8	38.6	47.4	52.0	59.0	66.2	73.4	79.8
3/4	42.6	46.6	52.4	64.5	72.5	81.5	91.0	99.0	109.0
1	62.4	66.0	77.4	88.5	100.5	115.0	128.0	150.0	154.5
1 1/4	80.5	94.0	97.0	117.0	139.0	171.0	201.0	221.1	230.0
1 1/2	99.5	109.5	127.0	137.0	165.0	197.0	207.0	233.0	243.0
2	137.0	155.0	166.5	194.6	220.0	260.0	290.0	319.0	346.0
2 1/2	204.0	216.0	237.5	285.0	315.0	354.6	405.0	445.5	510.0
3	267.0	295.0	317.0	396.6	450.0	505.0	595.0	600.0	680.0
4	367.5	452.5	443.8	505.0	595.0	700.0	755.0	830.5	925.0



HOSE NIPPLES

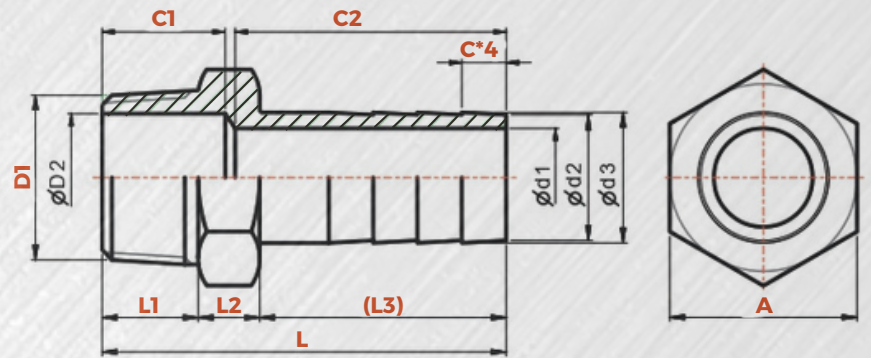

DESIGN FEATURES:

- ➡ THREAD: NPT
- ➡ CF8 (304) & CF8M (316)
- ➡ 2 1/2" NPT THREADED IS NOT AVAILABLE
- ➡ INCLUDING CF8 (304) ALL THREADS & CF8M (316) NPT THREAD

DIMENSIONS

Unit : inch

SIZE	A	D1	D2	C	C1	C2	L	L1	L2	(L3)	d1	d2	d3
1/4"	0.63	1/4"	0.26	0.16	0.67	1.10	1.83	0.51	0.39	0.93	0.20	0.31	0.35
3/8 "	0.75	3/8"	0.37	0.22	0.71	1.30	2.24	0.51	0.39	1.12	0.26	0.39	0.43
1/2"	0.98	1/2"	0.57	0.26	0.75	1.61	2.46	0.61	0.39	1.46	0.57	0.53	0.57
3/4 "	1.22	3/4"	0.71	0.33	0.91	1.89	2.85	0.71	0.45	1.69	0.57	0.77	0.81
1"	1.50	1"	1.02	0.35	0.98	2.17	3.23	0.77	0.49	1.97	0.79	1.00	1.05
1 1/4"	1.81	1 1/4 "	1.38	0.37	1.10	1.89	3.15	0.89	0.49	2.09	1.06	1.28	1.34
1 1/2 "	2.05	1 1/2 "	1.57	0.41	1.22	2.28	3.64	0.91	0.53	2.20	1.30	1.52	1.59
2 "	2.56	2"	2.03	0.51	1.30	2.91	4.31	0.96	0.59	2.76	1.77	1.99	2.07
2 1/2"	3.15	2 1/2"	2.64	0.63	1.46	3.74	5.35	1.06	0.63	3.66	2.08	2.44	2.52
3 "	3.78	3 "	3.07	0.67	1.69	3.94	5.79	1.30	0.67	3.82	2.76	2.95	3.07
4 "	4.72	4 "	4.02	0.83	1.89	4.13	6.22	1.42	0.71	4.09	3.54	3.98	4.09



HEX NIPPLES

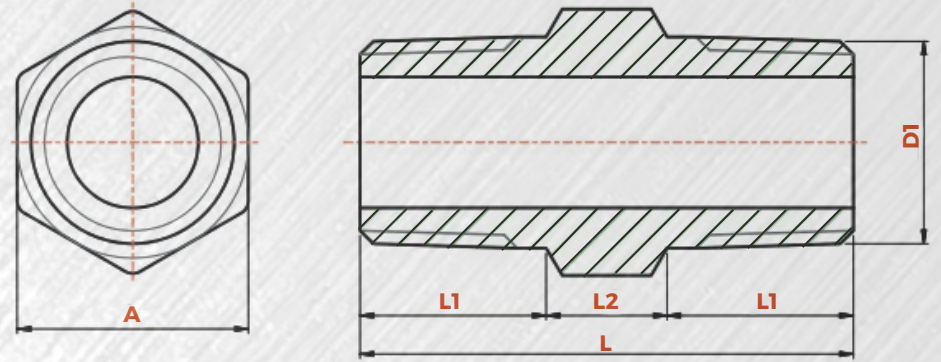

DESIGN FEATURES:
 → THREAD: NPT
 → CF8 (304) & CF8M (316)

DIMENSIONS

Unit : inch

SIZE	D1	A	L	L1	L2
1/8"	1/8"	0.51	1.22	0.47	0.28
1/4 "	1/4"	0.59	1.30	0.51	0.28
3/8"	3/8"	0.79	1.65	0.67	0.31
1/2 "	1/2"	0.91	1.97	0.79	0.39
3/4"	3/4"	1.14	2.01	0.79	0.43
1 "	1 "	1.42	2.48	1.00	0.47
1 1/4 "	1 1/4"	1.81	2.32	0.93	0.47
1 1/2"	1 1/2"	2.01	2.52	0.98	0.55
2"	2"	2.48	2.68	1.06	0.55
2 1/2"	2 1/2"	3.15	2.87	1.10	0.67
3 "	3 "	3.74	3.39	1.34	0.71
4 "	4"	4.72	3.54	1.42	0.71



REDUCING HEX NIPPLES

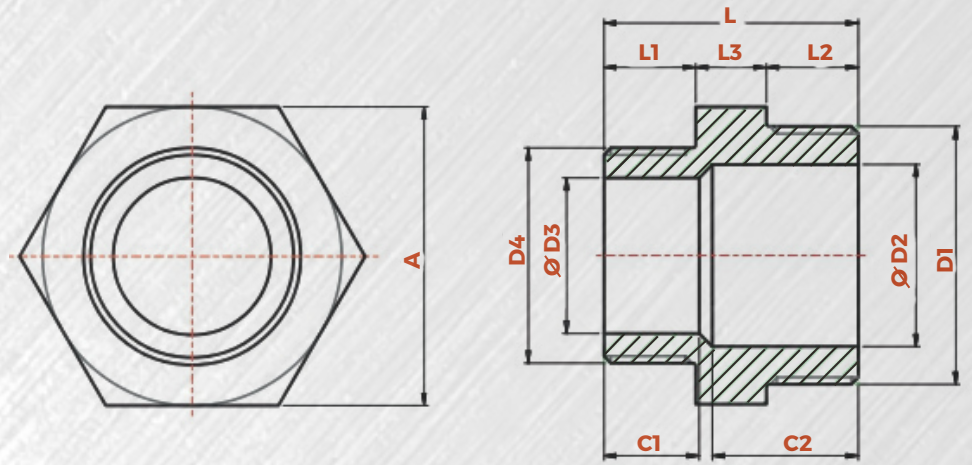

DESIGN FEATURES:
 → THREAD: NPT
 → CF8 (304) & CF8M (316)

DIMENSIONS

Unit : inch

SIZE	A	D1	D2	D3	D4	C1	C2	L	L1	L2	L3
1/4"x1/8"	0.67	1/4"	0.33	0.20	1/8"	0.47	0.71	1.24	0.43	0.47	0.33
3/8"x1/8"	0.83	3/8"	0.41	0.20	1/8"	0.43	0.83	1.38	0.43	0.51	0.39
3/8"x1/4"	0.83	3/8"	0.41	0.33	1/4"	0.55	0.79	1.38	0.47	0.51	0.39
1/2"x1/8"	1.02	1/2"	0.57	0.20	1/8"	0.47	0.83	1.54	0.47	0.67	0.39
1/2"x1/4"	1.02	1/2"	0.57	0.33	1/4"	0.47	0.87	1.54	0.47	0.67	0.39
1/2"x3/8"	1.02	1/2"	0.57	0.41	3/8"	0.59	0.87	1.54	0.51	0.63	0.39
3/4"x1/8"	1.26	3/4"	0.79	0.20	1/8"	0.47	1.06	1.61	0.41	0.75	0.45
3/4"x1/4"	1.26	3/4"	0.79	0.33	1/4"	0.59	1.02	1.65	0.47	0.75	0.45
3/4"x3/8"	1.26	3/4"	0.79	0.41	3/8"	0.47	0.98	1.65	0.47	0.75	0.45
3/4"x1/2"	1.26	3/4"	0.79	0.57	1/2"	0.67	0.98	1.77	0.59	0.75	0.45
1"x1/4"	1.50	1"	1.00	0.33	1/4"	0.59	1.10	1.79	0.53	0.79	0.47
1"x3/8"	1.50	1"	1.00	0.41	3/8"	0.59	1.10	1.77	0.51	0.79	0.47
1"x1/2"	1.50	1"	1.00	0.57	1/2"	0.71	1.10	1.89	0.63	0.79	0.47
1"x3/4"	1.50	1"	1.00	0.79	3/4"	0.79	1.14	2.01	0.75	0.79	0.47
1 1/4"x1/4"	1.81	1 1/4"	1.34	0.33	1/4"	0.59	1.14	1.85	0.55	0.83	0.47
1 1/4"x3/8"	1.81	1 1/4"	1.34	0.41	3/8"	0.71	1.18	1.93	0.55	0.91	0.47
1 1/4"x1/2"	1.81	1 1/4"	1.34	0.57	1/2"	0.71	1.18	2.01	0.55	0.87	0.47
1 1/4"x3/4"	1.81	1 1/4"	1.34	0.79	3/4"	0.75	1.26	2.17	0.75	0.94	0.47
1 1/4"x1"	1.81	1 1/4"	1.34	1.00	1"	0.87	1.14	2.13	0.79	0.87	0.47

